

## ULTRAMINI

Bohrungsbearbeitung  
ab  $\varnothing 0.2$  mm

grooving, boring and profiling  
starting at  $\varnothing 0.2$  mm

## Typ Gewindedrehen

metrisches ISO-Gewinde,  
Vollprofil, innen

type threading,  
metric ISO-thread,  
full profile, internal

D min. 2.4 - 7.0 mm  
Steigung P = 0.5 - 1.5

D min. 2.4 - 7.0 mm  
pitch P = 0.5 - 1.5

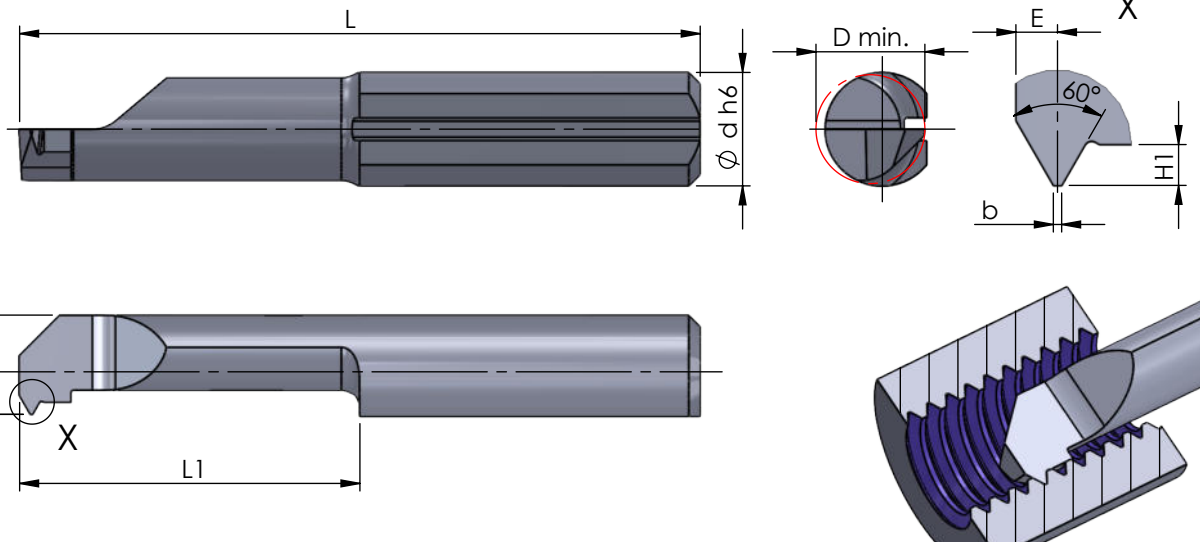

Rechts (R): wie gezeichnet  
Links (L): spiegelbildlich

righthand (R): as shown  
lefthand version (L): mirror image

Abmessungen in mm

dimensions in mm

Bestellnummer part number	Steigung P pitch P	Regelgewinde / standard thread	H1	E	b	f	a	L	L1	D min.	$\varnothing$ d h6	Klemmhalter Typ toolholder type				
												K10F	CN45F	AL41F	PD2F	
neu R/L 102.0205-10	0.5	M3	0.27	0.24	0.06	0.2	2.2	25	10	2.4	4.0		●			
neu R/L 102.0205-15	0.5	M3	0.27	0.24	0.06	0.2	2.2	30	15	2.4	4.0		●			
neu R/L 103.0307-15	0.7	M4	0.38	0.32	0.09	0.9	2.9	30	15	3.2	4.0		●			
neu R/L 103.0307-20	0.7	M4	0.38	0.32	0.09	0.9	2.9	35	20	3.2	4.0		●			640... ...4
R/L 104.0205-15	0.5		0.27	0.35	0.06	1.5	3.5	30	15	4.0	4.0		●			
R/L 104.0408-15	0.8	M5	0.43	0.5	0.10	1.5	3.5	30	15	4.0	4.0		●			
neu R/L 104.0408-25	0.8	M5	0.43	0.5	0.10	1.5	3.5	40	25	4.0	4.0		●			645...
R/L 105.0205-15	0.5		0.27	0.35	0.06	1.9	4.4	30	15	5.0	5.0		●			
R/L 105.0407-15	0.75		0.40	0.45	0.09	1.9	4.4	30	15	5.0	5.0		●			
R/L 105.0408-15	0.8		0.43	0.50	0.10	1.9	4.4	30	15	4.8	5.0		●			
R/L 105.0510-15	1.0	M6	0.54	0.55	0.12	1.9	4.4	30	15	4.8	5.0		●			
neu R/L 105.0510-20	1.0	M6	0.54	0.55	0.12	1.9	4.4	35	20	4.8	5.0		●			650... ...5
neu R/L 105.0510-25	1.0	M6	0.54	0.55	0.12	1.9	4.4	40	25	4.8	5.0		●			
neu R/L 105.0510-30	1.0	M6	0.54	0.55	0.12	1.9	4.4	45	30	4.8	5.0		●			
↳ ...																

Weitere HM Sorten können Sie in der Sortenübersicht im Kapitel "Technische Hinweise" und der Preisliste finden.

Bestellbeispiel:  
für rechte Ausführung und Sorte  
R102.0205-10/AL41F

### weitere Informationen:

- siehe Technische Hinweise

### more informations:

- look at the technical instructions

More carbide grades you can find in the grades summary in the chapter "technical instructions" and in the price list.

order-example:  
righthand version and grade  
R102.0205-10/AL41F