

# ULTRAMINI

Bohrungsbearbeitung  
ab  $\varnothing 0.2 \text{ mm}$

grooving, boring and profiling  
starting at  $\varnothing 0.2 \text{ mm}$

# Typ 610M

Axialstechen  
mit Eckenradius

face grooving  
with corner radius

D min. 6.0 mm  
Stechtiefe t max. 6.0 mm  
Nutbreite bis 3.0 mm

D min. 6.0 mm  
depth of groove t max. 6.0 mm  
width of groove up to 3.0 mm

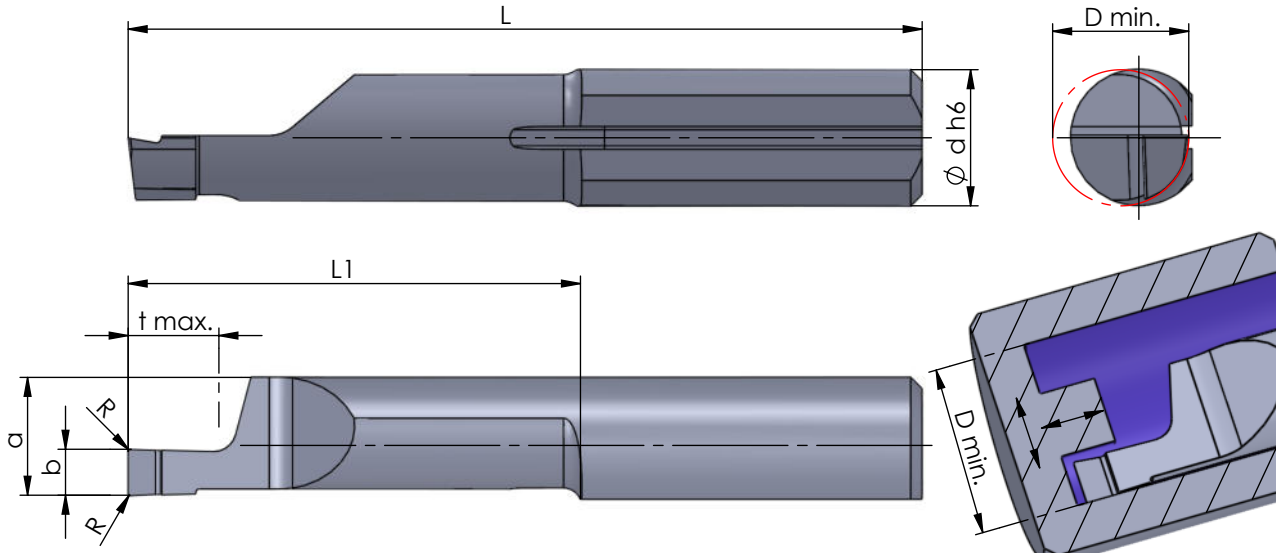

Rechts (R): wie gezeichnet  
Links (L): spiegelbildlich

righthand (R): as shown  
lefthand version (L): mirror image

Abmessungen in mm

dimensions in mm

Bestellnummer part number	b +0.05	a	L	L1	t max.	D min.	$\varnothing d h6$	R	Klemmhalter Typ toolholder type				
									K10F	CN45F	AL41F	P07C	
R/L 610M1008-10	1.0	5.2	26	11	2.0	6.0	6.0	0.1			●		
R/L 610M1508-10	1.5	5.2	26	11	3.0	6.0	6.0	0.1			●		
R/L 610M2008-10	2.0	5.2	26	11	4.0	6.0	6.0	0.1			●		
R/L 610M2508-10	2.5	5.2	26	11	5.0	6.0	6.0	0.1			●		
R/L 610M3008-10	3.0	5.2	26	11	6.0	6.0	6.0	0.1			●		
R/L 610M1008-20	1.0	5.2	35	20	2.0	6.0	6.0	0.1			●		
R/L 610M1508-20	1.5	5.2	35	20	3.0	6.0	6.0	0.1			●		
R/L 610M2008-20	2.0	5.2	35	20	4.0	6.0	6.0	0.1			●		
R/L 610M2508-20	2.5	5.2	35	20	5.0	6.0	6.0	0.1			●		
R/L 610M3008-20	3.0	5.2	35	20	6.0	6.0	6.0	0.1			●		
R/L 610M1008-30	1.0	5.2	45	30	2.0	6.0	6.0	0.1			●		
R/L 610M1508-30	1.5	5.2	45	30	3.0	6.0	6.0	0.1			●		
R/L 610M2008-30	2.0	5.2	45	30	4.0	6.0	6.0	0.1			●		
R/L 610M2508-30	2.5	5.2	45	30	5.0	6.0	6.0	0.1			●		
R/L 610M3008-30	3.0	5.2	45	30	6.0	6.0	6.0	0.1			●		

Weitere HM Sorten können Sie in der Sortenübersicht im Kapitel "Technische Hinweise" und der Preisliste finden.

Bestellbeispiel:  
für rechte Ausführung und Sorte  
R610M1008-10/AL41F

More carbide grades you can find in the grades summary in the chapter "technical instructions" and in the price list.

order-example:  
righthand version and grade  
R610M1008-10/AL41F