

# ULTRAMINI

Bohrungsbearbeitung  
ab  $\varnothing 0.2 \text{ mm}$

grooving, boring and profiling  
starting at  $\varnothing 0.2 \text{ mm}$

# Typ 010

Axialstechen  
mit Vollradius

face grooving  
with full radius

D min. 8.0 mm  
Stechtiefe t max. 6.0 mm  
Nutbreite bis 3.0 mm

D min. 8.0 mm  
depth of groove t max. 6.0 mm  
width of groove up to 3.0 mm

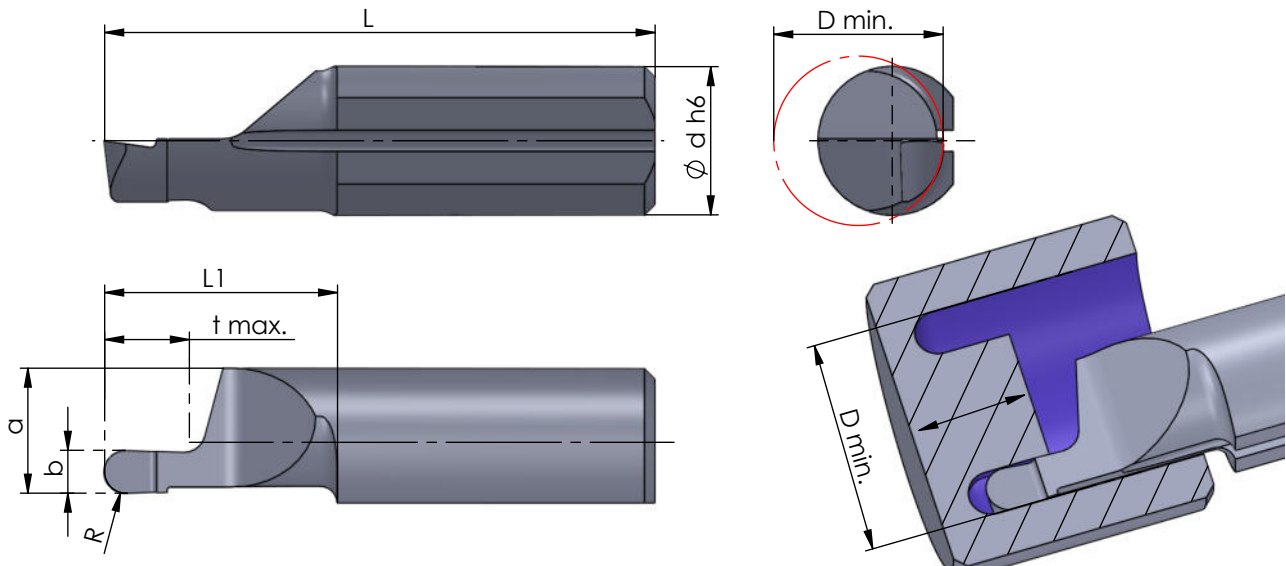

Rechts (R): wie gezeichnet  
Links (L): spiegelbildlich

righthand (R): as shown  
lefthand version (L): mirror image

Abmessungen in mm

dimensions in mm

Bestellnummer part number	b +0.05	b (inch)	R	a	L	L1	t max.	D min.	$\varnothing d h6$	Klemmhalter Typ toolholder type				
										K10F	CN45F	AL41F	PD2F	
R/L 010.1005-10	1.0		0.5	5.9	26	11	2.0	8.0	7.0			●	●	670... 676... 687... ...7
R/L 010.1507-10	1.57	0.062"	0.78	5.9	26	11	3.0	8.0	7.0			●		
R/L 010.1608-10	1.6		0.8	5.9	26	11	3.0	8.0	7.0			●	●	
R/L 010.1910-10	1.98	0.078"	0.99	5.9	26	11	4.0	8.0	7.0			●		
R/L 010.2010-10	2.0		1.0	5.9	26	11	4.0	8.0	7.0			●	●	
R/L 010.2512-10	2.5		1.25	5.9	26	11	5.0	8.0	7.0			●		
R/L 010.3015-10	3.0		1.5	5.9	26	11	6.0	8.0	7.0			●	●	
R/L 010.1005-20	1.0		0.5	5.9	35	20	2.0	8.0	7.0			●	●	
R/L 010.1608-20	1.6		0.8	5.9	35	20	3.0	8.0	7.0			●		
R/L 010.2010-20	2.0		1.0	5.9	35	20	4.0	8.0	7.0			●	●	
R/L 010.2512-20	2.5		1.25	5.9	35	20	5.0	8.0	7.0			●	●	
R/L 010.3015-20	3.0		1.5	5.9	35	20	6.0	8.0	7.0			●	●	

Weitere HM Sorten können Sie in der Sortenübersicht im Kapitel "Technische Hinweise" und der Preisliste finden.

Bestellbeispiel:  
für rechte Ausführung und Sorte  
R010.1005-10/AL41F

More carbide grades you can find in the grades summary in the chapter "technical instructions" and in the price list.

order-example:  
righthand version and grade  
R010.1005-10/AL41F