

MINICUT

Bohrungsbearbeitung

grooving, boring and profiling

Typ Stechdrehen

für Sicherungsringe DIN 471 / 472
und Stechdrehen allgemein

D min. 8 mm

type grooving,
for circlips DIN 471 / 472
and grooving

D min. 8 mm

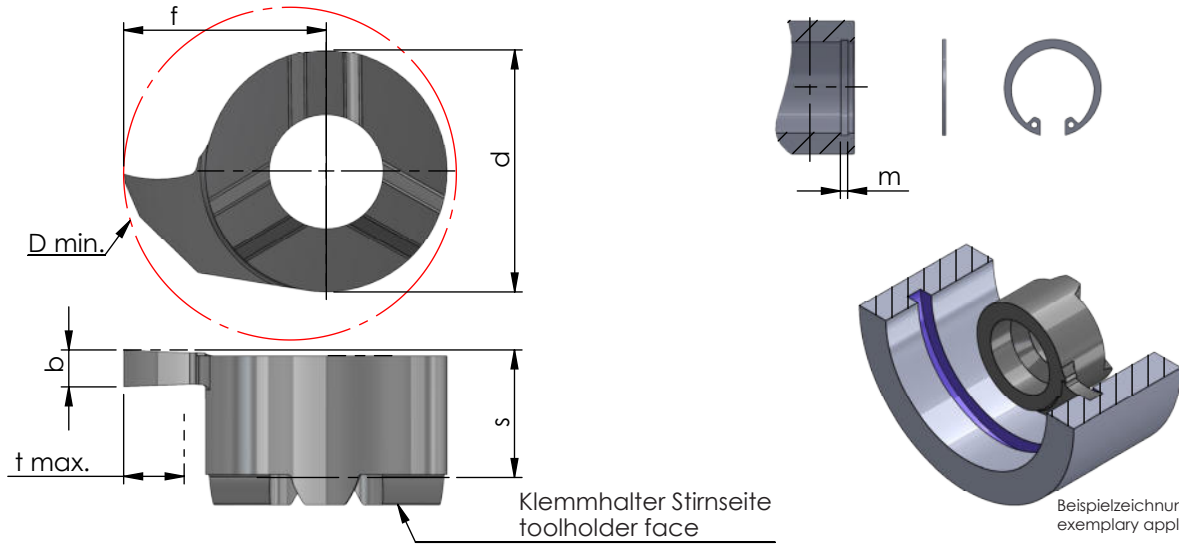

Rechts (R): wie gezeichnet
Links (L): spiegelbildlich

righthand (R): as shown
lefthand version (L): mirror image

Abmessungen in mm

dimensions in mm

| Bestellnummer part number | Nut-Maß m groove dim. m DIN 471 / DIN 472 | b +0.03 | b (inch) | f | s | d | t max. | D min. | Material | | | Klemmhalter Typ toolholder type |
|------------------------------|---|---------|----------|-----|-----|---|--------|--------|----------|-------|------|------------------------------------|
| | | | | | | | | | K10F | AL41F | P18C | |
| R/L S008.0070 | 0.7 | 0.73 | | 4.8 | 3.3 | 6 | 1.0 | 8 | | ● | | 608 |
| R/L S008.0079 | - | 0.79 | 0.031" | 4.8 | 3.3 | 6 | 1.0 | 8 | | ● | | |
| R/L S008.0080 | 0.8 | 0.83 | | 4.8 | 3.3 | 6 | 1.0 | 8 | | ● | | |
| R/L S008.0090 | 0.9 | 0.93 | | 4.8 | 3.3 | 6 | 1.0 | 8 | | ● | | |
| R/L S008.0099 | - | 0.99 | 0.039" | 4.8 | 3.3 | 6 | 1.0 | 8 | | ● | | |
| R/L S008.0100 | - | 1.00 | | 4.8 | 3.3 | 6 | 1.0 | 8 | ● | ● | | |
| R/L S008.0110 | 1.1 | 1.20 | | 4.8 | 3.3 | 6 | 1.0 | 8 | ● | ● | | |
| R/L S008.0117 | - | 1.17 | 0.046" | 4.8 | 3.3 | 6 | 1.0 | 8 | | ● | | |
| R/L S008.0130 | 1.3 | 1.40 | | 4.8 | 3.3 | 6 | 1.0 | 8 | | ● | | |
| R/L S008.0142 | - | 1.42 | 0.056" | 4.8 | 3.3 | 6 | 1.0 | 8 | | ● | | |
| R/L S008.0150 | - | 1.50 | | 4.8 | 3.3 | 6 | 1.0 | 8 | | ● | | |
| R/L S008.0157 | - | 1.57 | 0.062" | 4.8 | 3.3 | 6 | 1.0 | 8 | | ● | | |
| R/L S008.0160 | 1.6 | 1.70 | | 4.8 | 3.3 | 6 | 1.0 | 8 | | ● | | |
| R/L S008.0198 | - | 1.98 | 0.078" | 4.8 | 3.3 | 6 | 1.0 | 8 | | ● | | |
| R/L S008.0200 | - | 2.00 | | 4.8 | 3.3 | 6 | 1.0 | 8 | ● | ● | | |

Weitere HM Sorten können Sie in der Sortenübersicht im Kapitel "Technische Hinweise" und der Preisliste finden.

Bestellbeispiel:
für rechte Ausführung und Sorte
RS008.0070/AL41F

More carbide grades you can find in the grades summary in the chapter "technical instructions" and in the price list.

order-example:
righthand version and grade
RS008.0070/AL41F