

## MINICUT

Bohrungsbearbeitung

grooving, boring and profiling

## Typ Stechdrehen

für Sicherungsringe DIN 471 / 472  
und Stechdrehen allgemein

D min. 9 mm

type grooving,  
for circlips DIN 471 / 472  
and grooving

D min. 9 mm

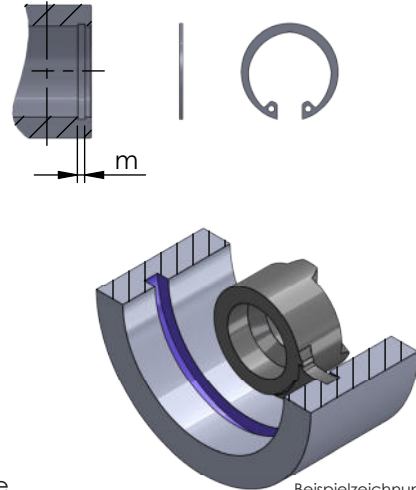
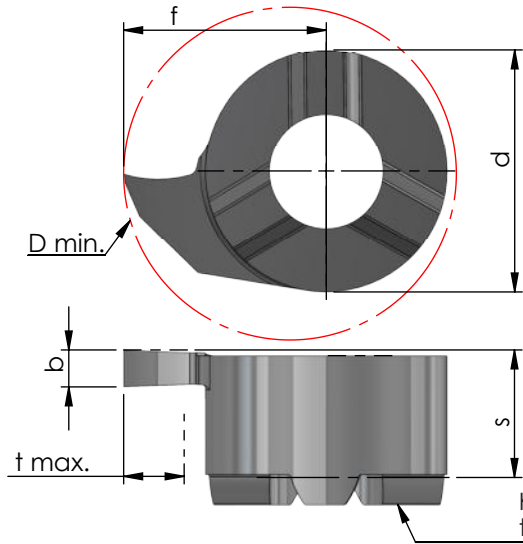

Rechts (R): wie gezeichnet  
Links (L): spiegelbildlich

righthand (R): as shown  
lefthand version (L): mirror image

Abmessungen in mm

dimensions in mm

Bestellnummer part number	Nut-Maß m groove dim. m DIN 471 / DIN 472	b +0.03	f	s	d	t max.	D min.	K10F	AL41F	P18C	Klemmhalter Typ toolholder type
R/L S009.0070	0.7	0.73	5.5	3.4	6.2	1.2	9	●			609
R/L S009.0080	0.8	0.83	5.5	3.4	6.2	1.3	9	●			
R/L S009.0090	0.9	0.93	5.5	3.4	6.2	1.5	9	●			
R/L S009.0100	-	1.00	5.5	3.4	6.2	1.8	9	●			
R/L S009.0110	1.1	1.20	5.5	3.6	6.2	1.8	9	●			
R/L S009.0130	1.3	1.40	5.5	3.6	6.2	1.8	9	●			
R/L S009.0150	-	1.50	5.5	3.6	6.2	1.8	9	●			
R/L S009.0160	1.6	1.70	5.5	3.6	6.2	1.8	9	●			
R/L S009.0200	-	2.00	5.5	3.6	6.2	1.8	9	●			
R/L S009.0250	-	2.50	5.5	3.6	6.2	1.8	9	●			
R/L S009.0300	-	3.00	5.5	3.6	6.2	1.8	9	●			

Weitere HM Sorten können Sie in der Sortenübersicht im Kapitel "Technische Hinweise" und der Preisliste finden.

Bestellbeispiel:  
für rechte Ausführung und Sorte  
RS009.0070/AL41F

More carbide grades you can find in the grades summary in the chapter "technical instructions" and in the price list.

order-example:  
righthand version and grade  
RS009.0070/AL41F