

MINICUT

Bohrungsbearbeitung

grooving, boring and profiling

Typ Stechdrehen

für Sicherungsringe DIN 471 / 472
und Stechdrehen allgemein

D min. 11 mm

type grooving,
for circlips DIN 471 / 472
and grooving

D min. 11 mm

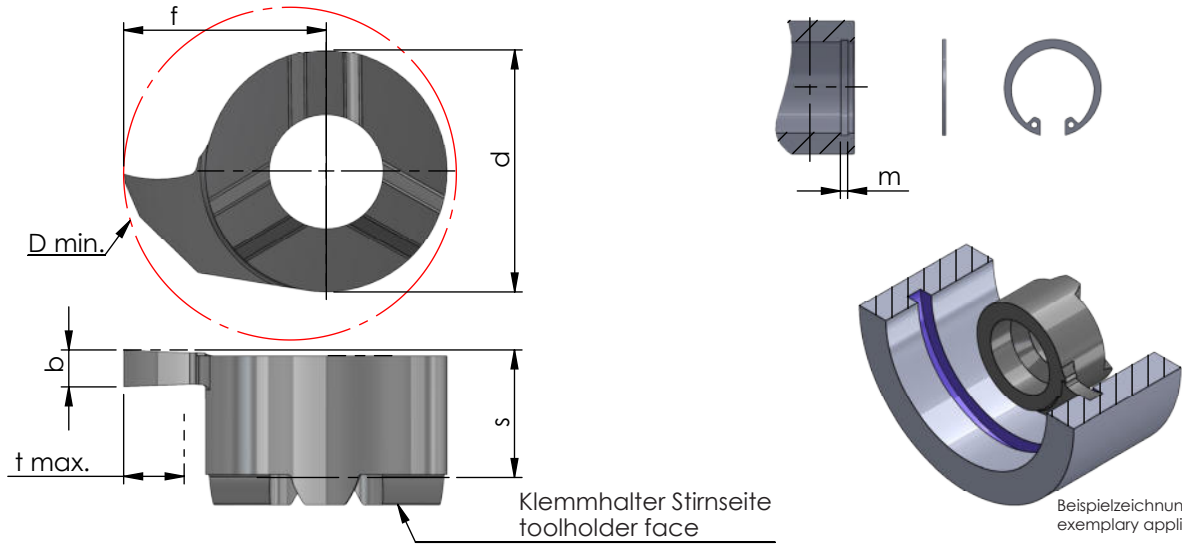

Rechts (R): wie gezeichnet
Links (L): spiegelbildlich

righthand (R): as shown
lefthand version (L): mirror image

Abmessungen in mm

dimensions in mm

Bestellnummer part number	Nut-Maß m groove dim. m DIN 471 / DIN 472	b +0.03	b (inch)	f	s	d	t max.	D min.				Klemmhalter Typ toolholder type
									K10F	AL41F	P18C	
R/L S011.0070	0.7	0.73		6.7	4.2	8	1.2	11		●		611
R/L S011.0080	0.8	0.83		6.7	4.2	8	1.3	11		●		
R/L S011.0090	0.9	0.93		6.7	4.2	8	1.5	11		●		
R/L S011.0099	-	0.99	0.039"	6.7	4.2	8	1.5	11		●		
R/L S011.0100	-	1.00		6.7	4.2	8	2.3	11	●	●		
R/L S011.0110	1.1	1.20		6.7	4.2	8	2.3	11	●	●		
R/L S011.0117	-	1.17	0.046"	6.7	4.2	8	2.3	11		●		
R/L S011.0130	1.3	1.40		6.7	4.2	8	2.3	11	●	●		
R/L S011.0150	-	1.50		6.7	4.2	8	2.3	11	●	●		
R/L S011.0157	-	1.57	0.062"	6.7	4.2	8	2.3	11		●		
R/L S011.0160	1.6	1.70		6.7	4.2	8	2.3	11	●	●		
R/L S011.0200	-	2.00		6.7	4.2	8	2.3	11	●	●		
R/L S011.0238	-	2.38	0.094"	6.7	4.2	8	2.3	11		●		
R/L S011.0250	-	2.50		6.7	4.2	8	2.3	11	●	●		
R/L S011.0300	-	3.00		6.7	4.2	8	2.3	11	●	●		

Weitere HM Sorten können Sie in der Sortenübersicht im Kapitel "Technische Hinweise" und der Preisliste finden.

Bestellbeispiel:
für rechte Ausführung und Sorte
RS011.0070/AL41F

More carbide grades you can find in the grades summary in the chapter "technical instructions" and in the price list.

order-example:
righthand version and grade
RS011.0070/AL41F