

MINICUT

Bohrungsbearbeitung

grooving, boring and profiling

Typ Stechdrehen

für Sicherungsringe DIN 471 / 472
und Stechdrehen allgemein

D min. 16 mm

type grooving,
for circlips DIN 471 / 472
and grooving

D min. 16 mm

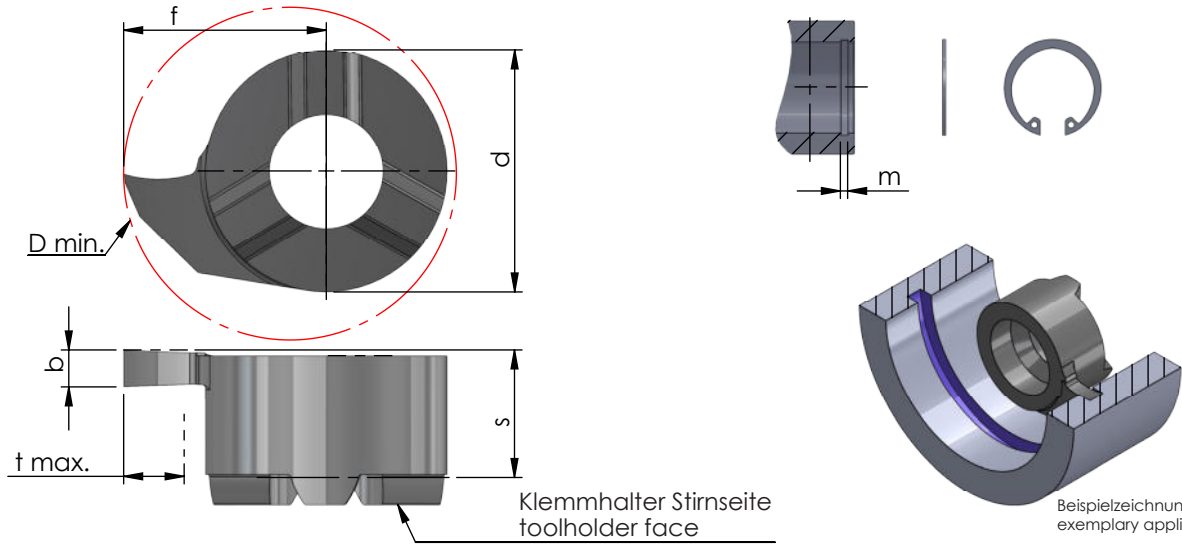

Rechts (R): wie gezeichnet
Links (L): spiegelbildlich

righthand (R): as shown
lefthand version (L): mirror image

Abmessungen in mm

dimensions in mm

Bestellnummer part number	Nut-Maß m groove dim. m DIN 471 / DIN 472	b +0.03	b (inch)	f	s	d	t max.	D min.	Klemmhalter Typ toolholder type			
									K10F	AL41F	P18C	
R/L S016.0070	0.7	0.73		10.2	5.2	11	1.2	16	●			616
R/L S016.0080	0.8	0.83		10.2	5.2	11	1.3	16		●		
R/L S016.0090	0.9	0.93		10.2	5.2	11	1.5	16		●		
R/L S016.0110	1.1	1.20		10.2	5.4	11	4.3	16	●	●		
R/L S016.0117	-	1.17	0.046"	10.2	5.4	11	4.3	16		●		
R/L S016.0130	1.3	1.40		10.2	5.4	11	4.3	16	●	●		
R/L S016.0150	-	1.50		10.2	5.4	11	4.3	16	●	●		
R/L S016.0157	-	1.57	0.062"	10.2	5.4	11	4.3	16		●		
R/L S016.0160	1.6	1.70		10.2	5.4	11	4.3	16	●	●		
R/L S016.0185	1.85	1.95		10.2	5.4	11	4.3	16	●	●		
↳ ...												

Weitere HM Sorten können Sie in der Sortenübersicht im Kapitel "Technische Hinweise" und der Preisliste finden.

Bestellbeispiel:
für rechte Ausführung und Sorte
RS016.0070/AL41F

More carbide grades you can find in the grades summary in the chapter "technical instructions" and in the price list.

order-example:
righthand version and grade
RS016.0070/AL41F