

# MINICUT

Bohrungsbearbeitung

grooving, boring and profiling

# Typ Stechdrehen

für Sicherungsringe DIN 471 / 472  
und Stechdrehen allgemein

D min. 16 mm

type grooving,  
for circlips DIN 471 / 472  
and grooving

D min. 16 mm

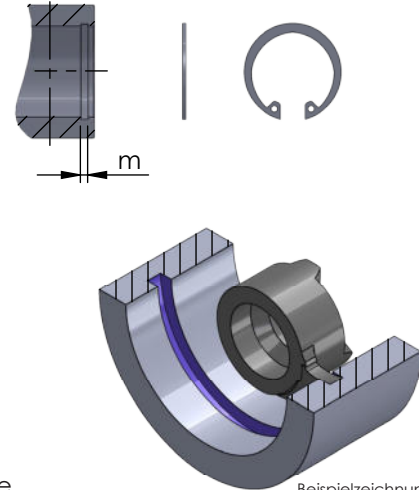
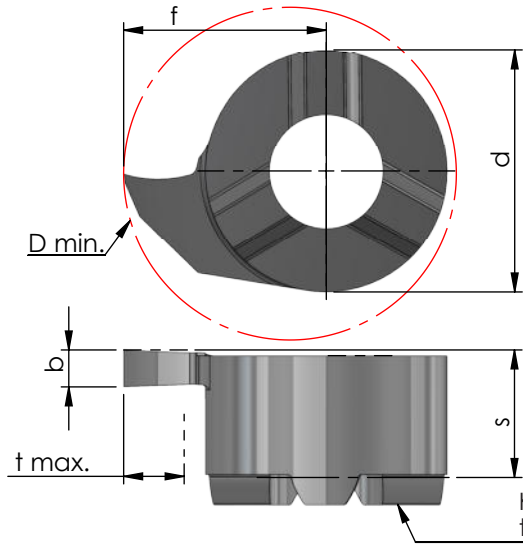

Rechts (R): wie gezeichnet  
Links (L): spiegelbildlich

righthand (R): as shown  
lefthand version (L): mirror image

Abmessungen in mm

dimensions in mm

Bestellnummer part number	Nut-Maß m groove dim. m DIN 471 / DIN 472		b +0.03	b (inch)	f	s	d	t max.	D min.	K10F	AL41F	P18C	Klemmhalter Typ toolholder type
⋮ ↙													
R/L S016.0200	-	-	2.00		10.2	5.4	11	4.3	16	●	●		616
R/L S016.0215	2.15	⊙	2.25		10.2	5.4	11	4.3	16	●	●		
R/L S016.0238	-	-	2.38	0.094"	10.2	5.4	11	4.3	16		●		
R/L S016.0250	-	-	2.50		10.2	5.4	11	4.3	16	●	●		
R/L S016.0265	2.65	⊙	2.75		10.2	5.4	11	4.3	16	●	●		
R/L S016.0300	-	-	3.00		10.2	5.4	11	4.3	16	●	●		
R/L S016.0315	3.15	⊙	3.28		10.2	5.4	11	4.3	16	●	●		
R/L S016.0350	-	-	3.50		10.2	5.4	11	4.3	16		●		
R/L S016.0400	-	-	4.00		10.2	5.4	11	4.3	16		●		
R/L S016.0415	4.15	⊙	4.28		10.2	5.4	11	4.3	16	●	●		

Weitere HM Sorten können Sie in der Sortenübersicht im Kapitel "Technische Hinweise" und der Preisliste finden.

Bestellbeispiel:  
für rechte Ausführung und Sorte  
RS016.0200/AL41F

More carbide grades you can find in the grades summary in the chapter "technical instructions" and in the price list.

order-example:  
righthand version and grade  
RS016.0200/AL41F