

# MINICUT

Bohrungsbearbeitung

grooving, boring and profiling

## Typ Axialstechen

am Zapfen vorbei

type face grooving,  
in pivots

D min. 12 / 16 mm  
Stechtiefe t max. 6 / 10 mm  
Nutbreite bis 3.0 / 4.0 mm

D min. 12 / 16 mm  
depth of groove t max. 6 / 10 mm  
width of groove up to 3.0 / 4.0 mm

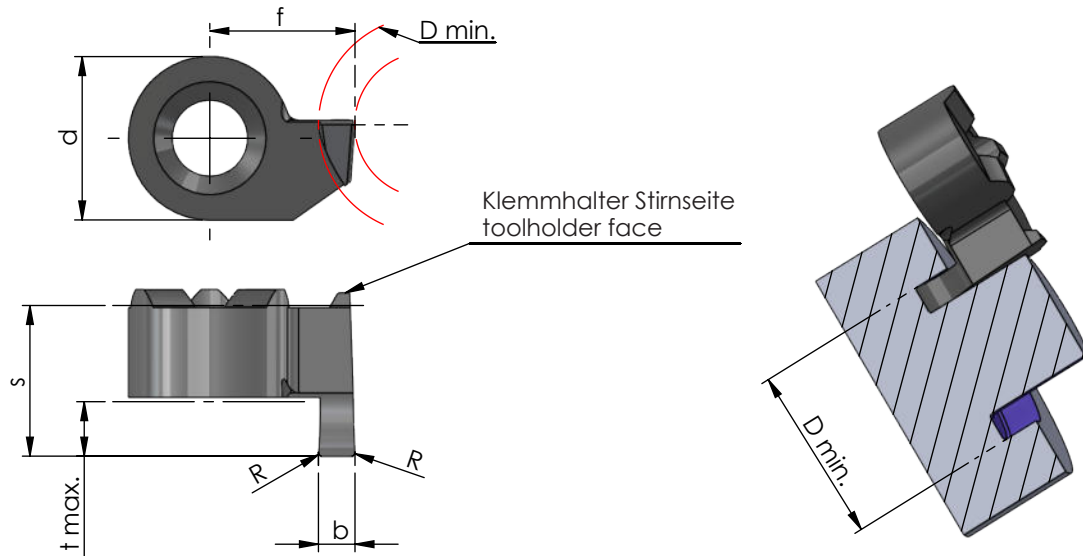

Rechts (R): wie gezeichnet  
Links (L): spiegelbildlich

righthand (R): as shown  
lefthand version (L): mirror image

Abmessungen in mm

dimensions in mm



Bestellnummer part number	b		f	R	s	d	t max.	D min.	K10F AL41F P18C	Klemhalter Typ toolholder type
	b+0.03	b (inch)								
R/L S014.1210.00	1.0		7.0	-	8.3	9	1.5	12	● ●	614 614.A
R/L S014.1215.02	1.5		7.5	0.2	8.3	9	2.5	12	● ●	
R/L S014.U219.02	1.98	0.078"	8.0	0.2	8.3	9	3.0	12	● ●	
R/L S014.1220.02	2.0		8.0	0.2	8.3	9	3.0	12	● ●	
R/L S014.U223.02	2.39	0.094"	8.4	0.2	8.3	9	3.0	12	● ●	
R/L S014.1225.02	2.5		8.5	0.2	8.3	9	3.0	12	● ●	
R/L S014.1230.02	3.0		9.0	0.2	8.3	9	3.0	12	● ●	
R/L S014.U231.02	3.18	0.125"	9.2	0.2	8.3	9	3.0	12	● ●	
R/L S014.1220.52	2.0		8.0	0.2	10.3	9	5.0	12	● ●	
R/L S014.U223.52	2.39	0.094"	8.4	0.2	10.3	9	5.0	12	● ●	
R/L S014.1225.52	2.5		8.5	0.2	10.3	9	5.0	12	● ●	
R/L S014.1230.52	3.0		9.0	0.2	10.3	9	5.0	12	● ●	
R/- S014.1230.62	3.0		9.0	0.2	11.3	9	6.0	12	● ●	
R/L S018.1630.02	3.0		11	0.2	15.8	11	10	16	● ●	618 618.A
R/L S018.1640.02	4.0		12	0.2	15.8	11	10	16	● ●	

Weitere HM Sorten können Sie in der Sortenübersicht im Kapitel "Technische Hinweise" und der Preisliste finden.

Bestellbeispiel:  
für rechte Ausführung und Sorte  
RS014.1210.00/AL41F

More carbide grades you can find in the grades summary in the chapter "technical instructions" and in the price list.

order-example:  
righthand version and grade  
RS014.1210.00/AL41F