

SWISSLINE

Miniatöraußenbearbeitung,
zweischneidig

miniature external machining,
two-cutting edges

Typ ZW10

Wendeschneidplatten,
zum Abstechen

indexable inserts
for parting off

Stechtiefe t max. = 6 - 16 mm
Stechbreite b = 0.8 - 3.0 mm

depth of groove t max. = 6 - 16 mm
width of groove b = 0.8 - 3.0 mm

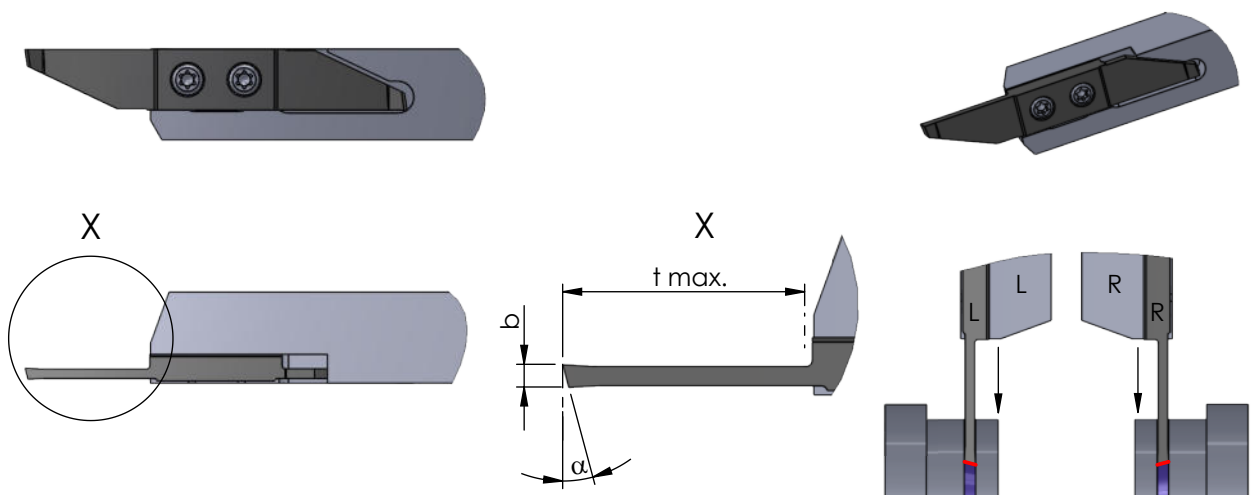

Rechts (R): wie gezeichnet
Links (L): spiegelbildlich

Rechte Schneidpl. in rechtem Halter
Linke Schneidpl. in linkem Halter

Abmessungen in mm

righthand version (R): as shown
lefthand version (L): mirror image

use RH insert in RH tool holder and
LH insert in LH tool holder

dimensions in mm



Bestellnummer part number	b	t max.	α					Klemmhalter Typ toolholder type
				K10F	CN45F	AL41F	P18C	
R/L ZW10.08061500	0.8	6	15°	●			●	R/L HW10... R/L HW15... R/L HW20...
R/L ZW10.08101500	0.8	10	15°	●			●	
R/L ZW10.10061500	1.0	6	15°	●			●	
R/L ZW10.10131500	1.0	13	15°	●			●	
R/L ZW10.12061500	1.2	6	15°	●			●	
R/L ZW10.15081500	1.5	8	15°	●			●	
R/L ZW10.15161500	1.5	16	15°	●			●	
R/L ZW10.18081500	1.8	8	15°	●			●	
R/L ZW10.20101500	2.0	10	15°	●			●	
R/L ZW10.20161500	2.0	16	15°	●			●	
R/L ZW10.25131500	2.5	13	15°	●			●	
R/L ZW10.25161500	2.5	16	15°	●			●	
R/L ZW10.30161500	3.0	16	15°	●			●	

Weitere HM Sorten können Sie in der Sorten-
übersicht im Kapitel "Technische Hinweise" und
der Preisliste finden.

Bestellbeispiel:
für rechte Ausführung und Sorte
RZW10.08061500/P18C

More carbide grades you can find in the grades
summary in the chapter "technical instructions"
and in the price list.

order-example:
righthand version and grade
RZW10.08061500/P18C