

SWISSLINE

Miniatöraußenbearbeitung,
zweischneidig

miniature external machining,
two-cutting edges

Typ ZW18

Wendeschneidplatten,
zum Abstechen unter 0°,
mit Spanformer

indexable inserts,
for parting off with 0°,
with chip former

Stechtiefe t max. = 10 - 16 mm
Stechbreite b = 1.5 - 3 mm

depth of groove t max. = 10 - 16 mm
width of groove b = 1.5 - 3 mm

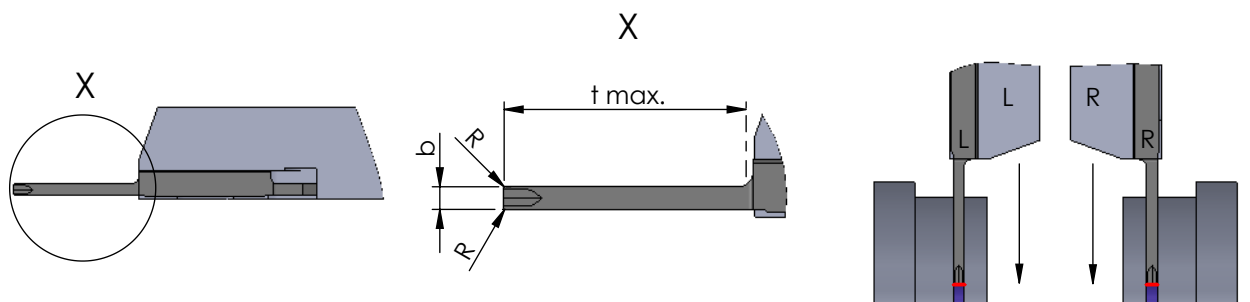
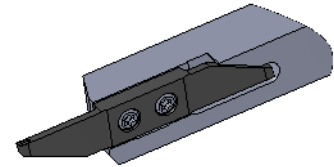

Rechts (R): wie gezeichnet
Links (L): spiegelbildlich

Rechte Schneidpl. in rechtem Halter
Linke Schneidpl. in linkem Halter

Abmessungen in mm

righthand version (R): as shown
lefthand version (L): mirror image

use RH insert in RH tool holder and
LH insert in LH tool holder

dimensions in mm



Bestellnummer part number	b	t max.	R	Klemmhalter Typ toolholder type			
				K10F	CN45F	AL41F	P18C
R/L ZW18.15100008	1.5	10	0.08	●			●
R/L ZW18.15160008	1.5	16	0.08	●			●
R/L ZW18.20100008	2.0	10	0.08	●			●
R/L ZW18.20160008	2.0	16	0.08	●			●
R/L ZW18.25130008	2.5	13	0.08	●			●
R/L ZW18.25160008	2.5	16	0.08	●			●
R/L ZW18.30160008	3.0	16	0.08	●			●

Weitere HM Sorten können Sie in der Sorten-
übersicht im Kapitel "Technische Hinweise" und
der Preisliste finden.

Bestellbeispiel:
für rechte Ausführung und Sorte
RZW18.15100008/P18C

More carbide grades you can find in the grades
summary in the chapter "technical instructions"
and in the price list.

order-example:
righthand version and grade
RZW18.15100008/P18C