

## SWISSLINE

Miniatúraußenbearbeitung,  
zweischneidig

miniature external machining,  
two-cutting edges

## Typ ZW19

Wendeschneidplatten,  
zum Abstechen unter 0°,  
mit Spantrepe

indexable inserts,  
for parting off with 0°,  
with chip breaker

Stechtiefe t max. = 10 - 16 mm  
Stechbreite b = 1.5 - 3 mm

depth of groove t max. = 10 - 16 mm  
width of groove b = 1.5 - 3 mm

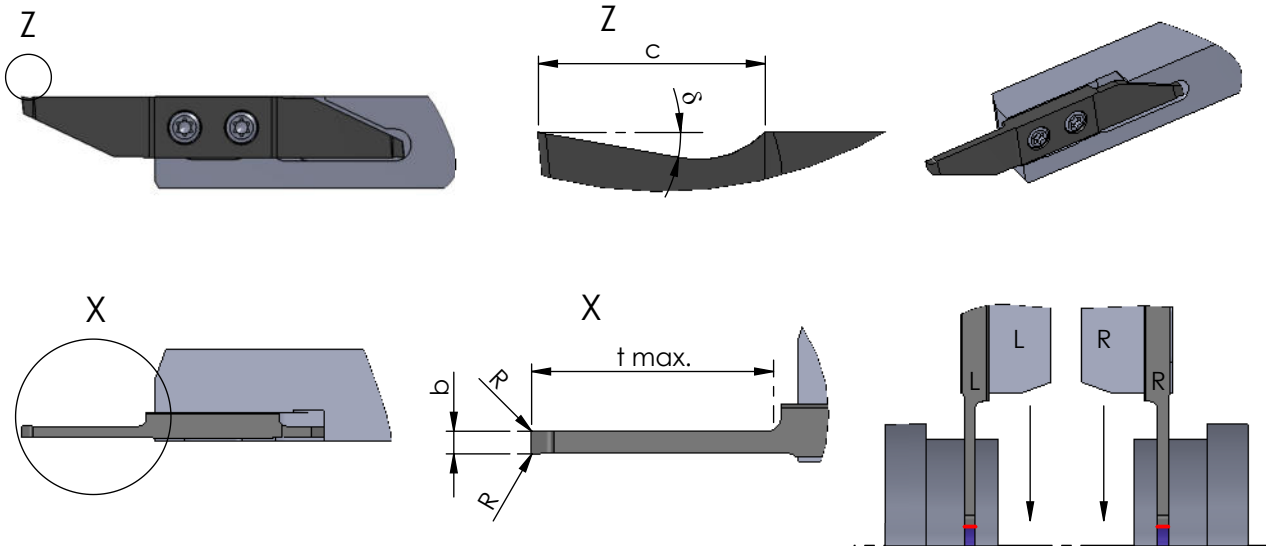

Rechts (R): wie gezeichnet  
Links (L): spiegelbildlich

Rechte Schneidpl. in rechtem Halter  
Linke Schneidpl. in linkem Halter

Abmessungen in mm

righthand version (R): as shown  
lefthand version (L): mirror image

use RH insert in RH tool holder and  
LH insert in LH tool holder

dimensions in mm

Bestellnummer part number	b	t max.	φ	R	c	Klemmhalter Typ toolholder type			
						K10F	CN45F	AL41F	P18C
R/L ZW19.15100605	1.5	10	6°	0.05	2	●			●
R/L ZW19.15101205	1.5	10	12°	0.05	2	●			●
R/L ZW19.20100605	2.0	10	6°	0.05	2	●			●
R/L ZW19.20101205	2.0	10	12°	0.05	2	●			●
R/L ZW19.20160605	2.0	16	6°	0.05	2	●			●
R/L ZW19.20161205	2.0	16	12°	0.05	2	●			●
R/L ZW19.25130605	2.5	13	6°	0.05	2	●			●
R/L ZW19.25131205	2.5	13	12°	0.05	2	●			●
R/L ZW19.25160605	2.5	16	6°	0.05	2	●			●
R/L ZW19.25161205	2.5	16	12°	0.05	2	●			●
R/L ZW19.30160605	3.0	16	6°	0.05	2	●			●
R/L ZW19.30161205	3.0	16	12°	0.05	2	●			●

Weitere HM Sorten können Sie in der Sorten-  
übersicht im Kapitel "Technische Hinweise" und  
der Preisliste finden.

Bestellbeispiel:  
für rechte Ausführung und Sorte  
RZW19.15100605/P18C

More carbide grades you can find in the grades  
summary in the chapter "technical instructions"  
and in the price list.

order-example:  
righthand version and grade  
RZW19.15100605/P18C