

# SWISSLINE

Miniatöraußenbearbeitung,  
zweischneidig

miniature external machining,  
two-cutting edges

# Typ ZW41

Wendeschneidplatten,  
Kopierdrehen hinten,  
mit Spanformer

indexable inserts,  
profiling at the back,  
with chipformer

Stechtiefe  $t$  max. = 11 mm  
Stechbreite  $b$  = 3.2 mm

depth of groove  $t$  max. = 11 mm  
width of groove  $b$  = 3.2 mm

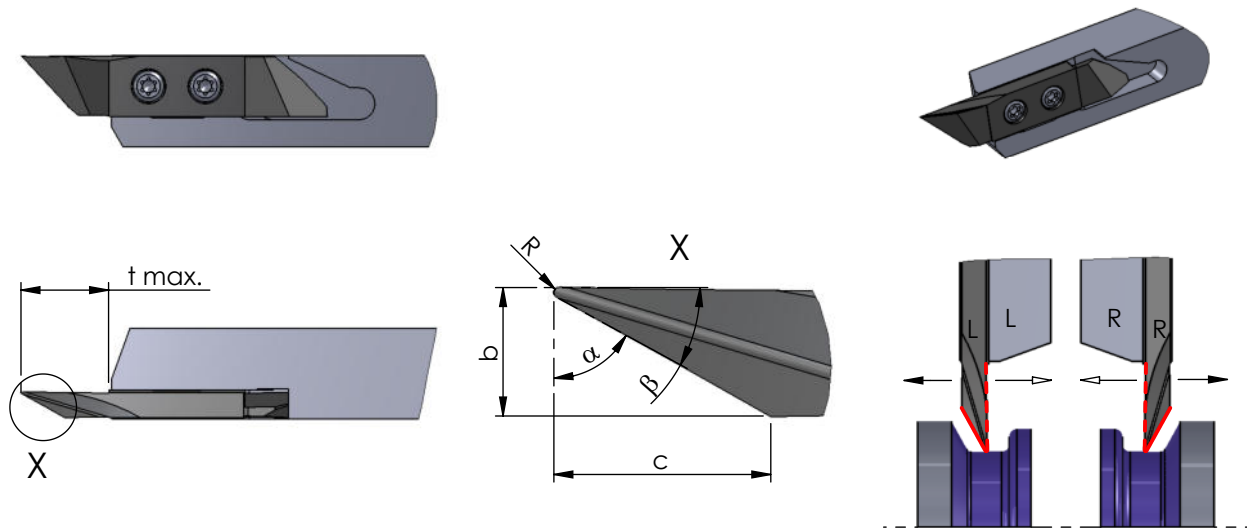

Rechts (R): wie gezeichnet  
Links (L): spiegelbildlich

Rechte Schneidpl. in rechtem Halter  
Linke Schneidpl. in linkem Halter

Abmessungen in mm

righthand version (R): as shown  
lefthand version (L): mirror image

use RH insert in RH tool holder and  
LH insert in LH tool holder

dimensions in mm



Bestellnummer part number	b	t max.	$\alpha$	R	$\beta$	c	Klemmhalter Typ toolholder type			
							K10F	CN45F	AL41F	P18C
R/L ZW41.32115515	3.2	11	55°	0.15	35°	4	●			
R/L ZW41.32115535	3.2	11	55°	0.35	35°	4	●			
R/L ZW41.32116108	3.2	11	61°	0.08	29°	5	●			R/L HW10,...
R/L ZW41.32116115	3.2	11	61°	0.15	29°	5	●			R/L HW15,...
R/L ZW41.32116135	3.2	11	61°	0.35	29°	5	●			R/L HW20,...
R/L ZW41.32116175	3.2	11	61°	0.75	29°	5	●			

Weitere HM Sorten können Sie in der Sorten-  
übersicht im Kapitel "Technische Hinweise" und  
der Preisliste finden.

Bestellbeispiel:  
für rechte Ausführung und Sorte  
RZW41.32115515/P18C

More carbide grades you can find in the grades  
summary in the chapter "technical instructions"  
and in the price list.

order-example:  
righthand version and grade  
RZW41.32115515/P18C