

SWISSLINE

Miniatöraußenbearbeitung,
zweischneidig

miniature external machining,
two-cutting edges

Typ ZW51

Wendeschneidplatten,
Kopierdrehen hinten,
mit Spanformer, Wipergeometrie

indexable inserts,
profiling at the back,
with chip former, wiper geometry

Stechtiefe t max. = 6 mm
Stechbreite b = 0.5 mm

depth of groove t max. = 6 mm
width of groove b = 0.5 mm

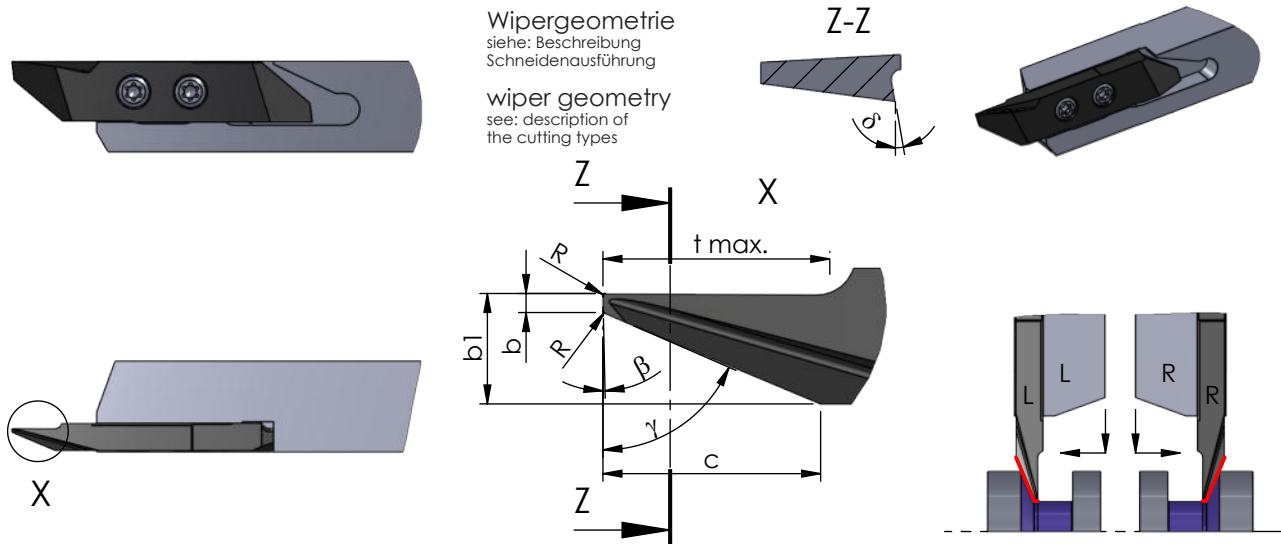

Rechts (R): wie gezeichnet
Links (L): spiegelbildlich

Rechte Schneidpl. in rechtem Halter
Linke Schneidpl. in linkem Halter

Abmessungen in mm

righthand version (R): as shown
lefthand version (L): mirror image

use RH insert in RH tool holder and
LH insert in LH tool holder

dimensions in mm



Bestellnummer part number	b	t max.	γ	R	b1	β	δ	c					Klemmhalter Typ toolholder type
									K10F	CN45F	AL41F	P18C	
R/L ZW51.05067000	0.5	6	70°	0	2.4	1.5°	15°	5	●			●	R/L HW10...
R/L ZW51.05067008	0.5	6	70°	0.08	2.4	1.5°	15°	5	●			●	R/L HW15...
R/L ZW51.05067015	0.5	6	70°	0.15	2.4	1.5°	15°	5	●			●	R/L HW20...

Weitere HM Sorten können Sie in der Sorten-
übersicht im Kapitel "Technische Hinweise" und
der Preisliste finden.

Bestellbeispiel:
für rechte Ausführung und Sorte
RZW51.05067000/P18C

More carbide grades you can find in the grades
summary in the chapter "technical instructions"
and in the price list.

order-example:
righthand version and grade
RZW51.05067000/P18C