

## SWISSLINE

Miniaturaußenbearbeitung,  
zweischneidig

miniature external machining,  
two-cutting edges

## Typ ZW90

Wendeschneidplatten,  
Gewindedrehen,  
Vollprofil, 60°

indexable inserts,  
threading,  
full profile, 60°

Gewinde M5 - M27  
Steigung P = 0.8 - 3

thread M5 - M27  
pitch P = 0.8 - 3

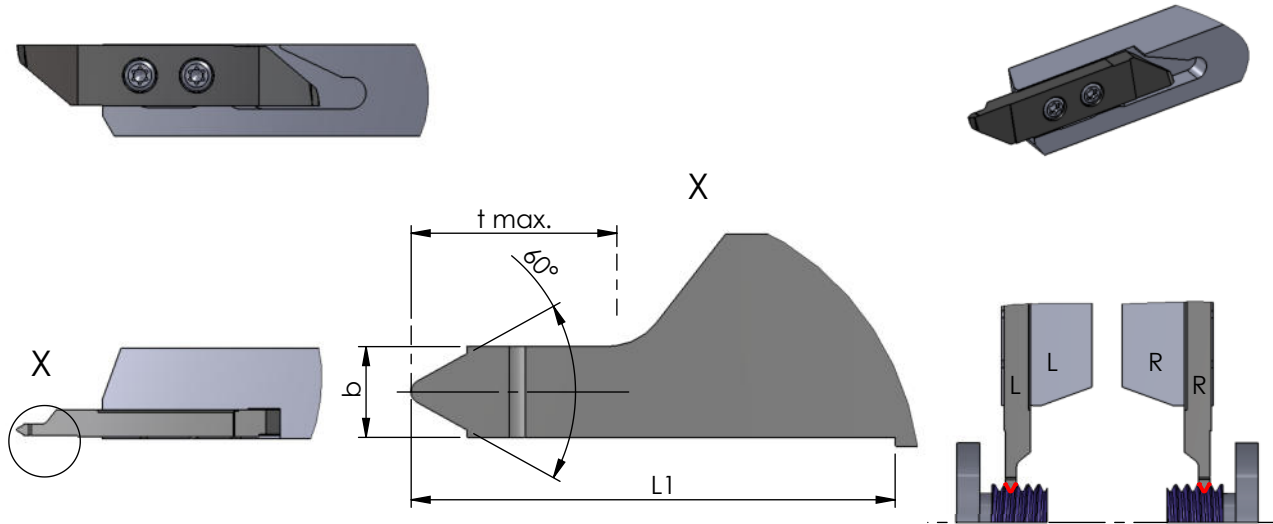

Rechts (R): wie gezeichnet  
Links (L): spiegelbildlich

Rechte Schneidpl. in rechtem Halter  
Linke Schneidpl. in linkem Halter

Abmessungen in mm

righthand version (R): as shown  
lefthand version (L): mirror image

use RH insert in RH tool holder and  
LH insert in LH tool holder

dimensions in mm



Bestellnummer part number	Gewindegröße thread size	Steigung P pitch P	b	L1	t max.					Klemmhalter Typ toolholder type
						K10F	CN45F	AL41F	P18C	
R/L ZW90.VP60080	M5	0.8	1.00	8	2.0	●			●	R/L HW10... R/L HW15... R/L HW20...
R/L ZW90.VP60100	M6 / M7	1.0	1.10	8	2.4	●			●	
R/L ZW90.VP60125	M8	1.25	1.46	8	2.9	●			●	
R/L ZW90.VP60150	M10 / M11	1.50	1.74	8	3.4	●			●	
R/L ZW90.VP60175	M12	1.75	1.96	8	3.9	●			●	
R/L ZW90.VP60200	M14 / M16	2.00	2.20	8	4.0	●			●	
R/L ZW90.VP60250	M18 / M20 / M22	2.50	2.80	8	5.0	●			●	
R/L ZW90.VP60300	M24 / M27	3.00		8	5.0	●			●	

Weitere HM Sorten können Sie in der Sorten-  
übersicht im Kapitel "Technische Hinweise" und  
der Preisliste finden.

Bestellbeispiel:  
für rechte Ausführung und Sorte  
RZW90.VP60080/P18C

More carbide grades you can find in the grades  
summary in the chapter "technical instructions"  
and in the price list.

order-example:  
righthand version and grade  
RZW90.VP60080/P18C