

# SYSTEM DED

Einstecken mit dreischneidigen Wendeplatten

grooving with three-cutting edges indexable inserts

# Typ .0.660

Bohrstange, Innenbearbeitung

grooving boring bar, internal application

D min. 46  
Spannbereich S 0.5 - 6.5 mm

D min. 46  
holding capacity S 0.5 - 6.5 mm

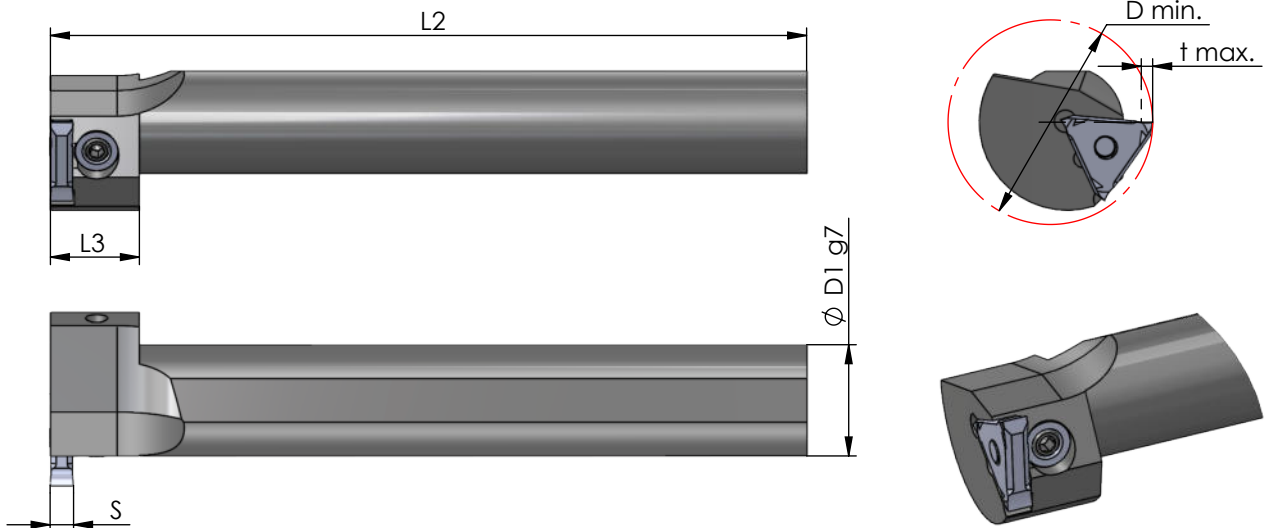

Rechts (R): wie gezeichnet  
Links (L): spiegelbildlich

righthand (R): as shown  
lefthand version (L): mirror image

Abmessungen in mm

dimensions in mm

Bestellnummer part number	Ø D1 g7	*D min.	*t max.	L2	L3	Spannpratze claw	Spannschraube screw	Spannbereich S holding capacity S	Wende- schneidplatte S indexable insert S
R/L .0.660.0025.1-D	25	46		170	20	PD.0.660.2	ZT300	0.5 - 2.0	
R/L .0.660.0032.1-D	32	46		200	20				
R/L .0.660.0040.1-D	40	46		250	-				
R/L .0.660.0025.2-D	25	46		170	20				
R/L .0.660.0032.2-D	32	46		200	20			1.9 - 3.0	
R/L .0.660.0040.2-D	40	46		250	-				
R/L .0.660.0025.3-D	25	46		170	20				
R/L .0.660.0032.3-D	32	46		200	20				
R/L .0.660.0040.3-D	40	46		250	-			2.9 - 4.0	
R/L .0.660.0025.4-D	25	46		170	20				
R/L .0.660.0032.4-D	32	46		200	20				
R/L .0.660.0040.4-D	40	46		250	-				

*D min.	46	50	60	80	100
*Stechtiefe t max. / max. depth of groove	2	3	4	4.5	5

Bestellbeispiel:  
für rechte Ausführung  
R.0.660.0025.1-D

order-example:  
righthand version  
R.0.660.0025.1-D

