

SYSTEM DED

Einstecken mit dreischneidigen Wendeplatten

grooving with three-cutting edges indexable inserts

Typ Stechdrehen

Wendeschneidplatte, zum Feindreihen

indexable insert, for finishing

Stechbreite S 1.0 - 4.0 mm

width of groove S 1.0 - 4.0 mm

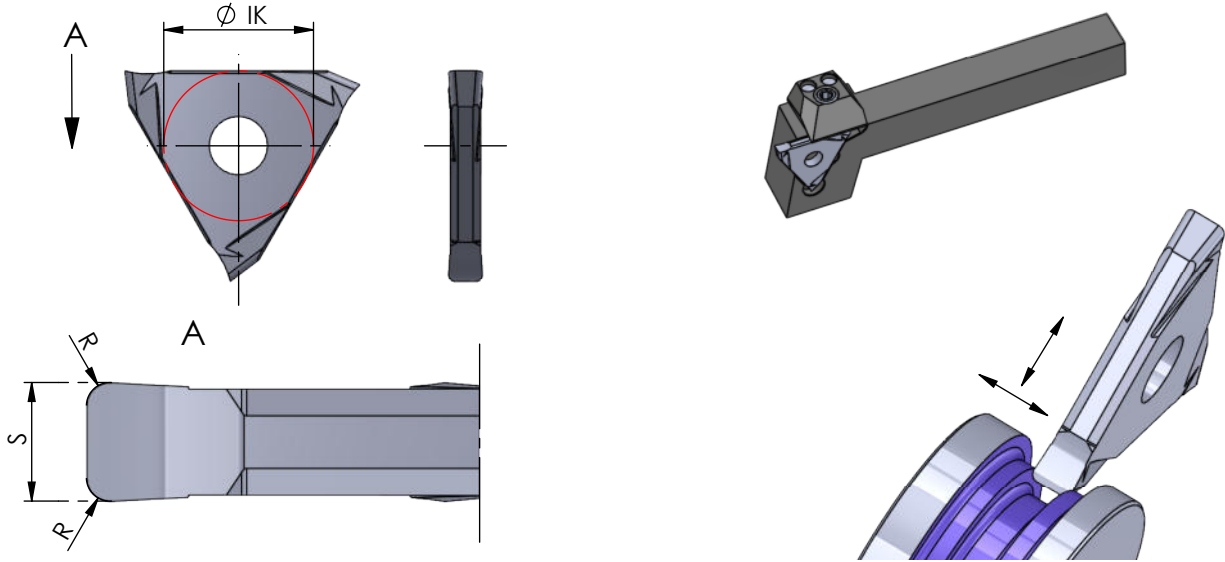

Wendeschneidplatten sind in rechten und linken Klemmhaltern sowie Bohrstängen verwendbar

inserts can be used in RH and LH toolholders as well as in boring bars

Abmessungen in mm

dimensions in mm



Bestellnummer part number	S +0.03	R	Ø IK					Klemmhalter Typ toolholder type
				K10F	CN45F	AL41F	P07C	
DED.0100.02	1.0	0.2	13.0	●		●		
DED.0150.02	1.5	0.2	13.0	●	●	●		R/L .207.1-D R/L .0.738.1-D (R/L .0.660.1-D)
DED.0200.02	2.0	0.2	13.2	●	●	●		
DED.0200.04	2.0	0.4	13.2	●	●	●		
DED.0300.02	3.0	0.2	13.2	●	●	●		R/L .207.2-D R/L .0.738.2-D (R/L .0.780.2-D) (R/L .0.660.2-D)
DED.0300.06	3.0	0.6	13.2	●	●	●		
DED.0300.08	3.0	0.8	13.2	●	●	●		
DED.0400.02	4.0	0.2	13.2	●	●	●		R/L .207.3-D R/L .0.738.3-D (R/L .0.780.3-D) (R/L .0.660.3-D)
DED.0400.08	4.0	0.8	13.2	●	●	●		
DED.0400.12	4.0	1.2	13.2	●	●	●		

Weitere HM Sorten können Sie in der Sortenübersicht im Kapitel "Technische Hinweise" und der Preisliste finden.

More carbide grades you can find in the grades summary in the chapter "technical instructions" and in the price list.

Bestellbeispiel:
für Sorte AL41F:
DED.0100.02/AL41F

order-example:
grade AL41F:
DED.0100.02/AL41F