

NUTSTOSEN

von Längsnuten nach
DIN 138 und DIN 6885

broaching keyways according
DIN 138 und DIN 6885

Typ NPV

Schneideinsatz
Nuttiefe bis 10 mm,
Toleranzklassen JS9

B = 5 - 20

insert
depth of groove up to 10 mm,
tolerance grade JS9

B = 5 - 20

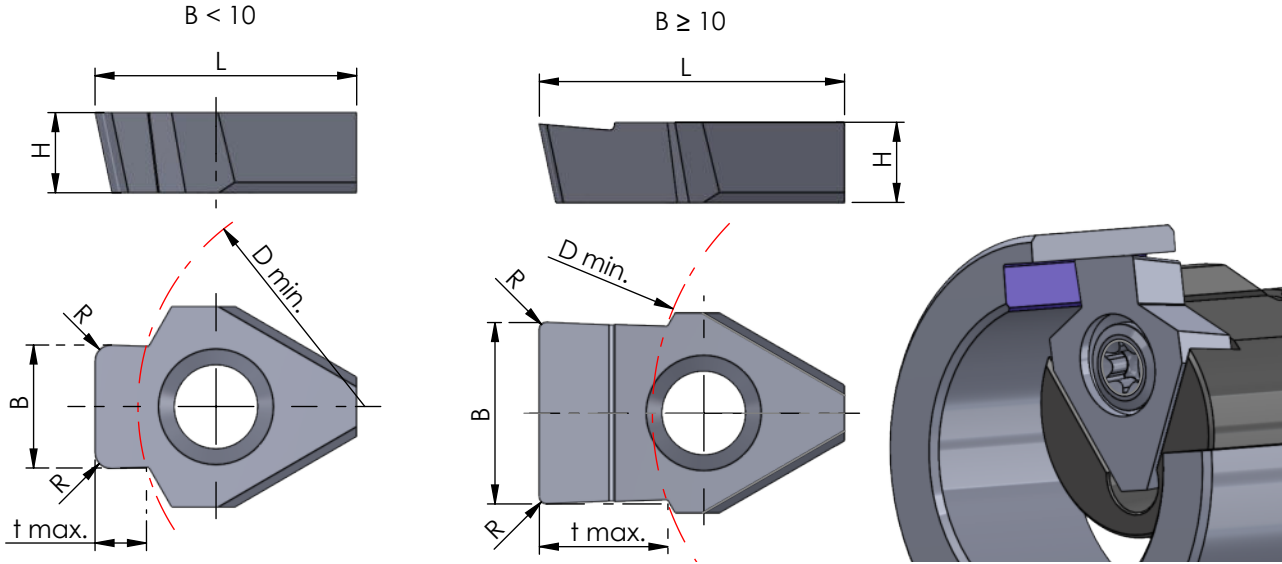

Abmessungen in mm

dimensions in mm

Bestellnummer part number	Nenngröße nominal size	Schneideinsatz nach DIN insert according DIN	B	R	L	t max.	H	Material			für Klemhalter for toolholder type
								K10F	AL41F	P18C	
NPV.0501.02	5		5.01	0.2	17.3	2.7	5.3	●			NHV.22....
NPV.0601.02	6		6.01	0.2	17.3	3.4	5.3	●			NHV.22....
NPV.0801.02	8		8.01	0.2	17.3	4.1	5.3	●			NHV.30. ... (NHV.22)
NPV.1001.03	10		10.01	0.3	17.3	4.2	5.3	●			NHV.30. ... (NHV.22)
NPV.1202.03	12	JS9 DIN 6885	12.02	0.3	20.1	5.7	5.3	●			NHV.38. ... (NHV.30/22. ...)
NPV.1202.05	12	leichter Sitz slightly fit	12.02	0.5	20.1	8.5	5.3	●			NHV.38. ... (NHV.30/22. ...)
NPV.1402.03	14		14.02	0.3	20.1	7.5	6.3	●			NHV.45. ... (NHV.38/30/22. ...)
NPV.1602.03	16		16.02	0.3	20.1	7.5	6.3	●			NHV.45. ... (NHV.38/30/22. ...)
NPV.1802.05	18		18.02	0.4	20.1	9.5	6.3	●			NHV.45. ... (NHV.38/30/22. ...)
NPV.2002.05	20		20.02	0.5	20.1	10	6.3	●			NHV.45. ... (NHV.38/30/22. ...)

Klemhalter in Klammer sind nicht optimal in der Unterstützung. Schnittwerte reduzieren! Weitere HM Sorten können Sie in der Sortenübersicht im Kapitel "Technische Hinweise" und der Preisliste finden.

Bestellbeispiel:
für Sorte AL41F:
NPV.0501.02/AL41F

Please note that toolholders in brackets are not the optimal choice. If using them, please reduce the cutting data!

More carbide grades you can find in the grades summary in the chapter "technical instructions" and in the price list.

order-example:
grade AL41F:
NPV.0501.02/AL41F