

NUTSTOSEN

von Längsnuten nach
DIN 138 und DIN 6885

broaching keyways according
DIN 138 und DIN 6885

Typ NPU.SW

Schneideinsatz
für Innensechskant

insert
for hexagon socket

Schlüsselweite ab SW 2.5 - 8 mm

wrench size from 2.5 - 8 mm

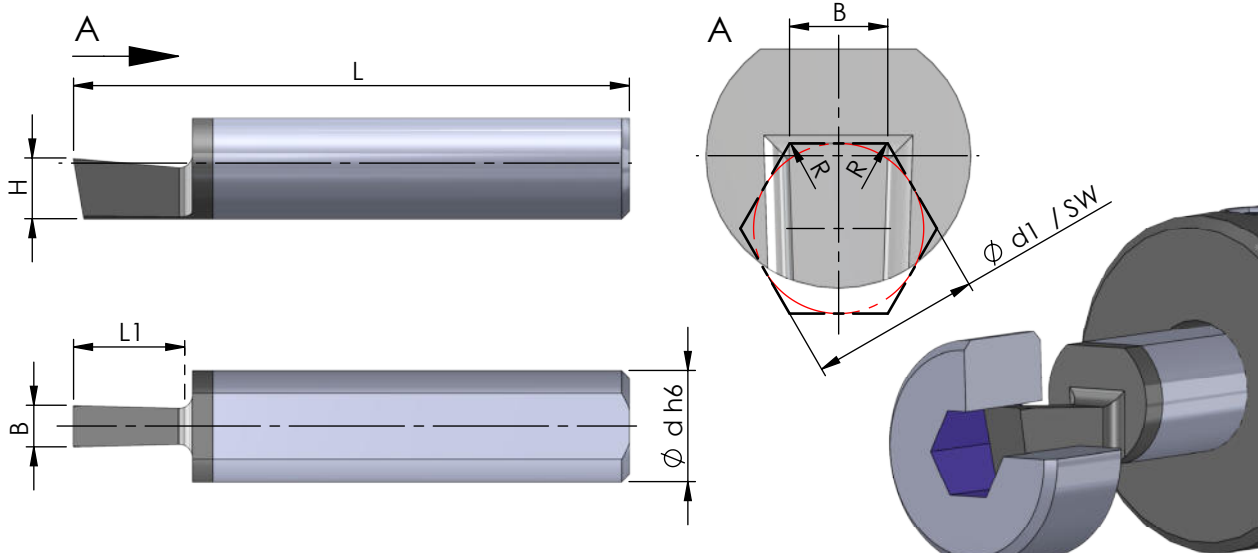

Nutmaß nach DIN

width of the groove according to DIN

Abmessungen in mm

dimensions in mm

Bestellnummer part number	Schlüsselweite SW wrench size	Ø d1 Bohrung Ø d1 hole	B	H +0.05	R	L	L1	Ø d h6				für Klemmhalter for toolholder type
									K10F	AL41F	P18C	
NPU.SW25.25.01	2.5	2.5	1.48	2.0	0.05	30	4.5	7		●		NHU...
NPU.SW30.30.01	3.0	3.0	1.77	2.5	0.05	30	5.0	7		●		
NPU.SW35.35.01	3.5	3.5	2.07	2.9	0.05	30	6.0	7		●		
NPU.SW40.40.01	4.0	4.0	2.35	3.3	0.05	35	6.5	7		●		
NPU.SW45.45.01	4.5	4.5	2.64	3.8	0.1	35	7.5	7		●		
NPU.SW50.50.01	5.0	5.0	2.95	4.2	0.1	35	9.5	7		●		
NPU.SW60.60.01	6.0	6.0	3.53	5.2	0.1	35	9.5	7		●		
NPU.SW80.80.01	8.0	8.0	4.70	5.7	0.1	37	12.5	7		●		

Weitere HM Sorten können Sie in der Sortenübersicht im Kapitel "Technische Hinweise" und der Preisliste finden.

Bestellbeispiel:
für Sorte AL41F:
NPU.SW25.25.01/AL41F

More carbide grades you can find in the grades summary in the chapter "technical instructions" and in the price list.

order-example:
grade AL41F:
NPU.SW25.25.01/AL41F