

MIKROMILL

Nut- und Formzirkularfräsen

groove milling
by circular interpolation

Typ MA3 / MA5

metrisches ISO-Gewinde,
Teilprofil, innen

metric ISO-thread,
partial profile, internal

ab Gewindegröße M2 x 0.4

starting at thread size M2 x 0.4

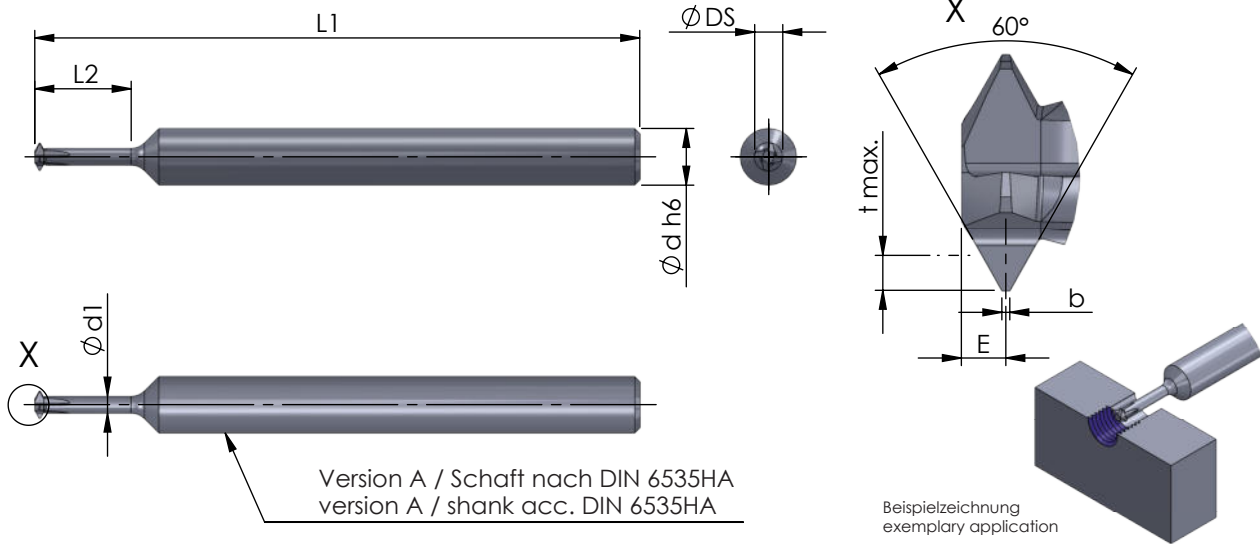

Abmessungen in mm

dimensions in mm

Bestellnummer part number	min. Gewindegröße min. thread size	Steigung P pitch P	L2	L1	b	E	t max.	Ø d h6	Ø d1	Ø DS	Schneidenzahl cutting edge			
												K10F	AL41F	P18C
MA3.MR20.01-5	M2	0.4-0.45	5	32	0.05	0.3	0.27	3	0.77	1.45	4	●		
MA3.MR25.01-6	M2.5	0.45-0.5	6	32	0.05	0.3	0.29	3	1.06	1.8	4	●		
MA3.MR30.01-7	M3	0.5-0.6	7	32	0.06	0.3	0.35	3	1.27	2.15	4	●		
MA3.MR35.01-8	M3.5	0.6-0.7	8	32	0.07	0.4	0.40	3	1.39	2.4	4	●		
MA5.MR40.01-9	M4	0.7-0.8	9	44	0.08	0.4	0.46	5	1.58	2.7	4	●		
MA5.MR50.01-10	M5	0.8-1.0	10	44	0.1	0.5	0.59	5	2.14	3.57	4	●		
MA5.MR60.01-12	M6	1.0-1.25	12.2	44	0.12	0.6	0.74	5	2.44	4.2	4	●		
MA5.MR70.01-15	M7	1.0-1.25	15.2	44	0.12	0.6	0.74	5	3.09	4.9	4	●		

Weitere HM Sorten können Sie in der Sortenübersicht im Kapitel "Technische Hinweise" und der Preisliste finden.

Bestellbeispiel:
für Sorte AL41F:
MA3.MR20.01-5/AL41F

More carbide grades you can find in the grades summary in the chapter "technical instructions" and in the price list.

order-example:
grade AL41F:
MA3.MR20.01-5/AL41F