

MIKROMILL

Nut- und Formzirkularfräsen

groove milling
by circular interpolation

Typ MB6 / MB8

metrisches ISO-Feingewinde,
Teilprofil, innen

metric ISO-fine thread,
partial profile, internal

ab Gewindegröße M7 x 0,5

starting at thread size M7 x 0,5

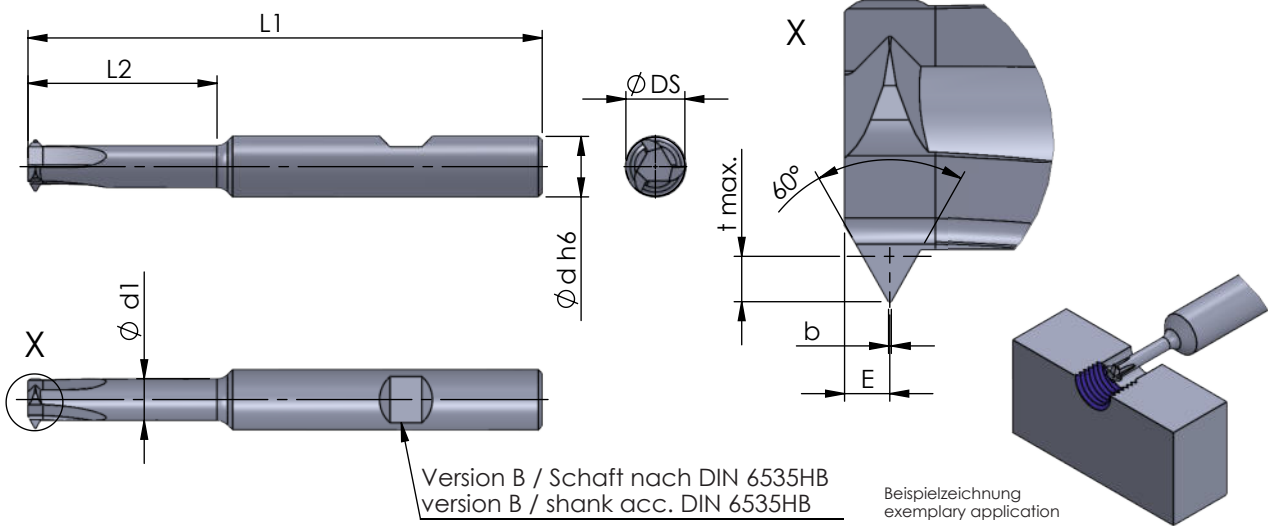

Beispielzeichnung
exemplary application

Abmessungen in mm

dimensions in mm

Bestellnummer part number	min. Gewindegröße min. thread size	Steigung P pitch P	L2	L1	b	E	t max.	Ø d h6	Ø d1	Ø DS	Schneidenzahl cutting edge	K10F	AL41F	P18C
												●	●	●
MB6.0815.01-15	M7	0.5-1.5	15	58	0.06	0.8	0.91	6	3.5	5.8	3	●	●	●
MB8.0815.01-25	M9	0.5-1.5	25	68	0.06	1.0	0.91	8	5.5	7.8	3	●	●	●
MB8.1020.01-25	M10	1.0-2.0	25	68	0.12	1.0	1.19	8	5.0	7.8	3	●	●	●

Weitere HM Sorten können Sie in der Sortenübersicht im Kapitel "Technische Hinweise" und der Preisliste finden.

Bestellbeispiel:
für Sorte AL41F:
MB6.0815.01-15/AL41F

More carbide grades you can find in the grades summary in the chapter "technical instructions" and in the price list.

order-example:
grade AL41F:
MB6.0815.01-15/AL41F