

MINIMILL

Nut- und Formzirkularfräsen

groove milling by circular interpolation

Typ ZH8

Frälerschaft Stahl

milling shank steel

D min. 7 mm

D min. 7 mm

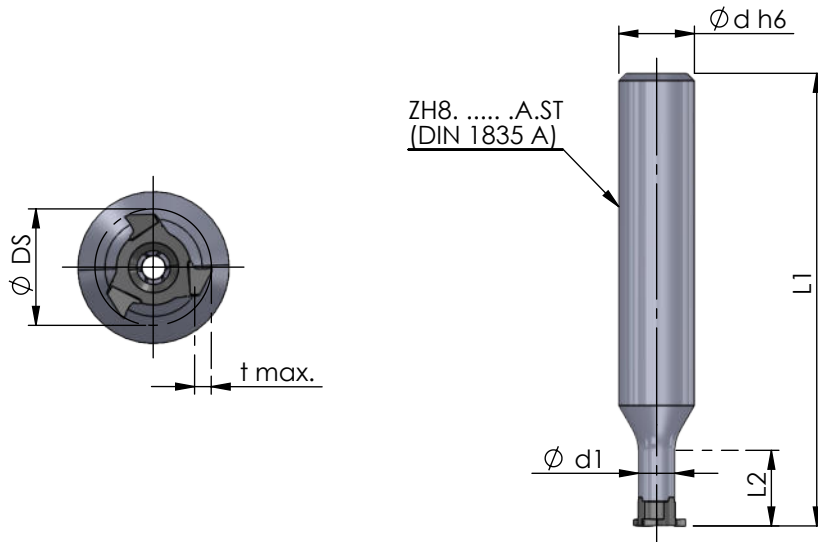

Abmessungen in mm

dimensions in mm



neu

Bestellnummer part number	Ø d h6	Ø d1	L1	L2	Typ: t max./ Schneidkreis-Ø DS	Spannschraube screw	Schraubenschlüssel wrench	Anzugs- drehmoment torque	für Schneideinsatz for insert
ZH8.1005.10.A.ST	10	4.8	60	10	Z8: 0.6 / 6.7 Z8: 1.1 / 7.7 Z8: 1.6 / 8.7 Z8: 2.6 / 10.7	M2-MM	T7F	1.2 Nm	Z8...

Bestellbeispiel:
ZH8.1005.10.A.ST

order-example:
ZH8.1005.10.A.ST