

# MINIMILL

Nut- und Formzirkularfräsen

groove milling by circular interpolation

# Typ ZH14

Frälerschaft Stahl

milling shank steel

D min. 14 mm

D min. 14 mm

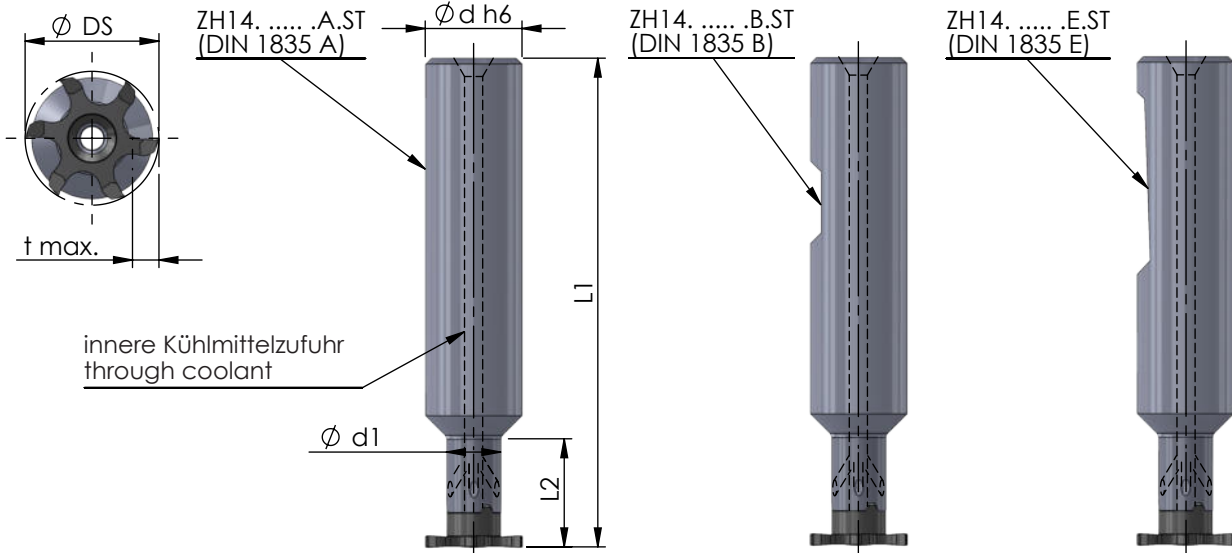

Abmessungen und Beschreibungen gelten für alle Varianten

dimensions and descriptions are valid for all versions

Abmessungen in mm

dimensions in mm

Bestellnummer part number					Typ: t max./ Schneidkreis- $\phi DS$	Spannschraube screw	Schraubenschlüssel wrench	Anzugs- drehmoment torque	für Schneideinsatz for insert
	$\phi d h6$	d1	L1	L2					
ZH14.0808.15.A.ST	8	8	50	15	Z14: 2.5 / 13.7 Z16: 3.5 / 15.7 Z616: 3.5 / 15.7	M3.5-MM	T10F	3.5 Nm	Z14... Z16... Z614... Z616...
ZH14.1008.17.A.ST	10	8	60	17					
ZH14.1308.25.A.ST	13	8	70	25					
ZH14.1608.16.A.ST /...B.ST /...E.ST	16	8	80	16					

Bestellbeispiel:  
ZH14.0808.15.A.ST

order-example:  
ZH14.0808.15.A.ST