

MINIMILL

Nut- und Formzirkularfräsen

groove milling by circular interpolation

Typ ZH14.ER

Fräseschaft,
für Spannzangenfutter (DIN 6499)

D min. 14 mm

milling shank,
for collet chucks (DIN 6499)

D min. 14 mm

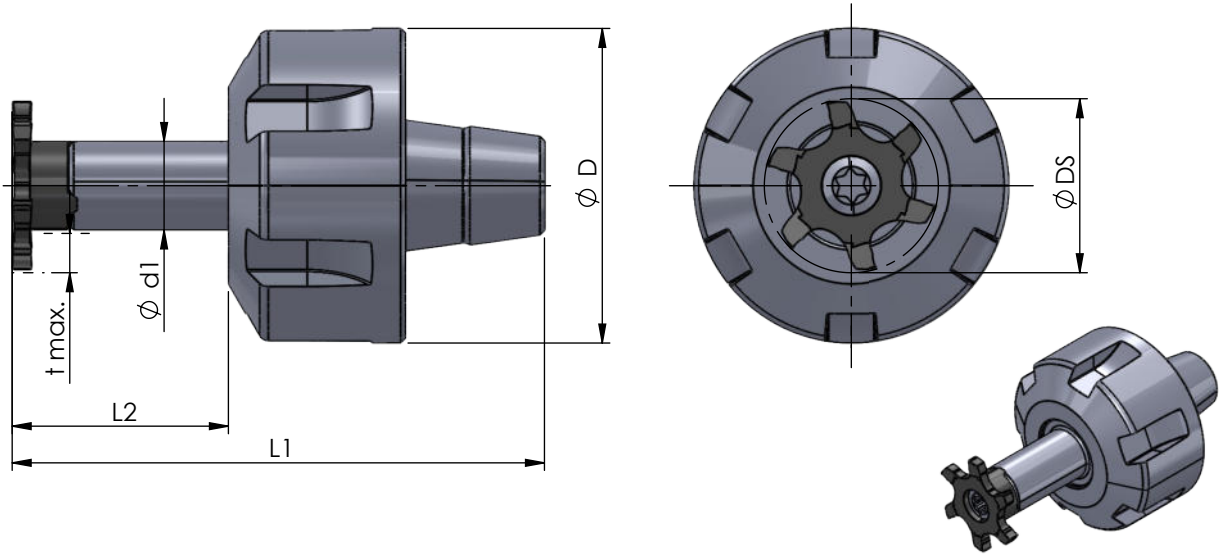

Abmessungen und Beschreibungen
gelten für alle Varianten

dimensions and descriptions are
valid for all versions

Abmessungen in mm

dimensions in mm

Bestellnummer part number	Ø d1	L2	Ø D	L1	Spannmutter / Gewinde clamping nut / thread	Typ: t max./ Schneidkreis-Ø DS	Spannschraube screw	Schraubenschlüssel wrench	Anzugs- drehmoment torque	für Schneideinsatz for insert
ZH14.ER11.0816.19	8	16	19	36.3	ER11.1219.SP / M14x0.75	Z14: 2.5 / 13.7 Z16: 3.5 / 15.7 Z616: 3.5 / 15.7	M3.5-MM	T10F	3.5 Nm	Z14... Z16... Z614... Z616...
ZH14.ER11.0816.16	8	16	16	36.3	ER11.1216.SP / M13x0.75					
ZH14.ER16.0822.32	8	22	32	52.0	ER16.1832.SP / M22x1.5					
ZH14.ER16.0822.22	8	22	22	52.0	ER16.1822.SP / M19x1.0					
ZH14.ER16.0822.25	8	22	25	52.0	ER16.1825.SP / M19x1.0					
ZH14.ER20.0822.35	8	22	35	56.5	ER20.1935.SP / M25x1.5					
ZH14.ER20.0822.28	8	22	28	56.5	ER20.1928.SP / M24x1.0					

Bestellbeispiel:
ZH14.ER11.0816.19

order-example:
ZH14.ER11.0816.19