

MINIMILL

Nut- und Formzirkularfräsen

groove milling by circular interpolation

Typ ZH18

Fräferschaft Stahl

milling shank steel

D min. 18 mm

D min. 18 mm

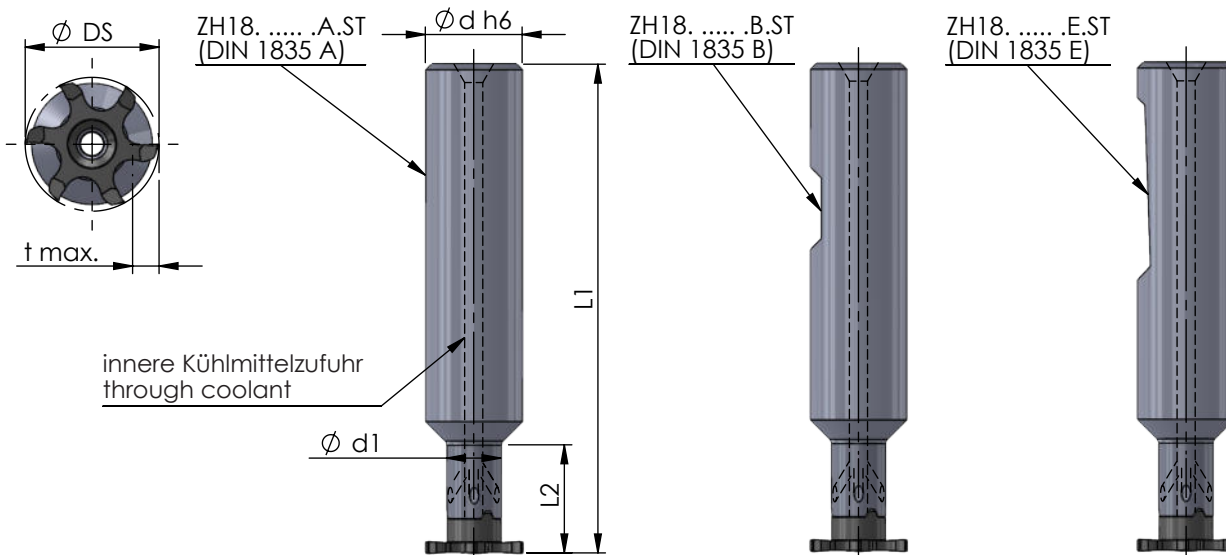

Abmessungen und Beschreibungen gelten für alle Varianten

dimensions and descriptions are valid for all versions

Abmessungen in mm

dimensions in mm



Bestellnummer part number					Typ: t max./ Schneidkreis- ϕDS	Spannschraube screw	Schraubenschlüssel wrench	Anzugs- drehmoment torque	für Schneideinsatz for insert
	$\phi d h6$	d1	L1	L2					
ZH18.1009.17.A.ST	10	9	60	17	Z18: 3.5 / 17.7 Z618: 4 / 17.7 Z620: 5 / 19.7	M4-MM	T15F	4.5 Nm	Z18... Z618... Z620...
ZH18.1309.25.A.ST	13	9	70	25					
ZH18.1609.18.A.ST /...B.ST /...E.ST	16	9	80	18					

Bestellbeispiel:
ZH18.1609.18.A.ST

order-example:
ZH18.1609.18.A.ST