

**MINIMILL**

Nut- und Formzirkularfräsen

groove milling by circular interpolation

**Typ ZH18**

Frälerschaft Hartmetall

D min. 18 mm

milling shank carbide

D min. 18 mm

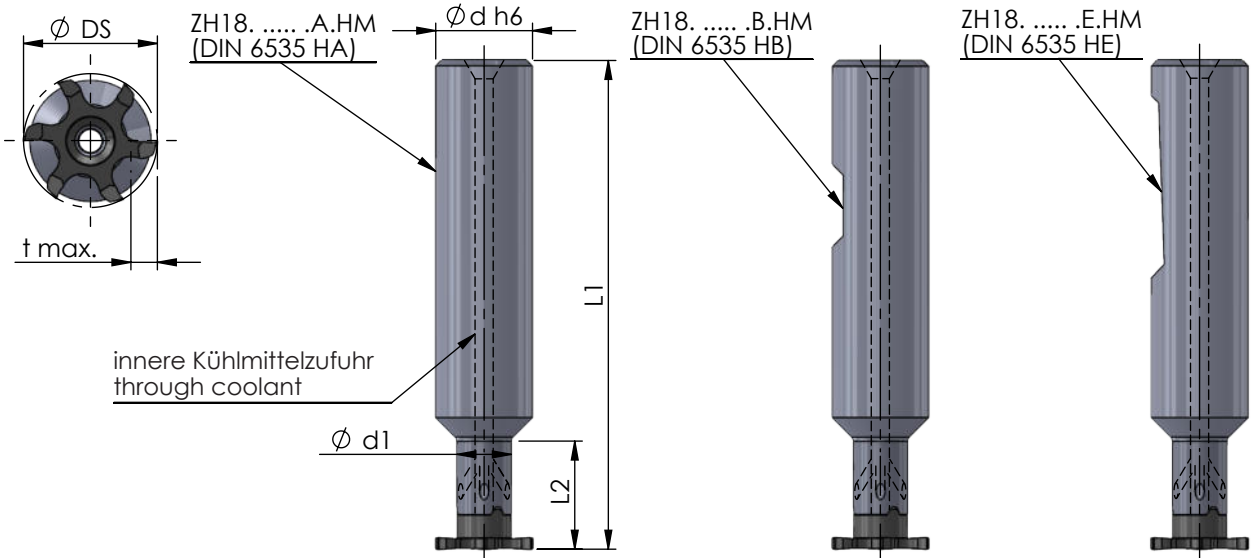

Abmessungen und Beschreibungen gelten für alle Varianten

dimensions and descriptions are valid for all versions

Abmessungen in mm

dimensions in mm

Bestellnummer part number	Ø d h6	Ø d (inch)	Ø d1	L1	L2	Typ: t max./ Schneidkreis-Ø DS	Spannschraube screw	Schraubenschlüssel wrench	Anzugs- drehmoment torque	für Schneideinsatz for insert
ZH18.1209.32.A.HM /...B.HM /...E.HM	12		9	100	32	Z18: 3.5 / 17.7 Z618: 4 / 17.7 Z620: 5 / 19.7	M4-MM	T15F	4.5 Nm	Z18... Z618... Z620...
ZH18.U1209.32.A.HM /...B.HM	12.7	1/2"	9	100	32					
ZH18.1209.45.A.HM /...B.HM /...E.HM	12		9	100	45					
ZH18.U1209.45.A.HM /...B.HM	12.7	1/2"	9	100	45					
ZH18.1209.64.A.HM /...B.HM /...E.HM	12		9	120	64					
ZH18.U1209.64.A.HM /...B.HM	12.7	1/2"	9	120	64					
ZH18.U1509.45.A.HM /...B.HM	15.875	5/8"	9	110	45					
ZH18.1609.25.A.HM /...B.HM /...E.HM	16		9	93	25					
ZH18.1609.32.A.HM /...B.HM /...E.HM	16		9	100	32					
ZH18.1609.45.A.HM /...B.HM /...E.HM	16		9	110	45					
ZH18.1609.64.A.HM /...B.HM /...E.HM	16		9	130	64					
ZH18.1613.64.A.HM /...B.HM /...E.HM	16		13	110	64					
ZH18.1613.66.A.HM /...B.HM /...E.HM	16		13	130	66	t max. reduced				

Hinweis:  
Hartmetall-Frälerschäfte mit beschädigter  
Schneidplattenaufnahme können durch unseren  
Reparaturservice instand gesetzt werden.

note:  
carbide-toolholder with damaged seating can be  
repaired by Dümmel.

Bestellbeispiel:  
ZH18.1613.66.A.HM

order-example:  
ZH18.1613.66.A.HM