

## MINIMILL

Nut- und Formzirkularfräsen

groove milling by circular interpolation

## Typ ZH18.ER

Fräseschaft,  
für Spannzangenfutter (DIN 6499)

D min. 18 mm

milling shank,  
for collet chucks (DIN 6499)

D min. 18 mm

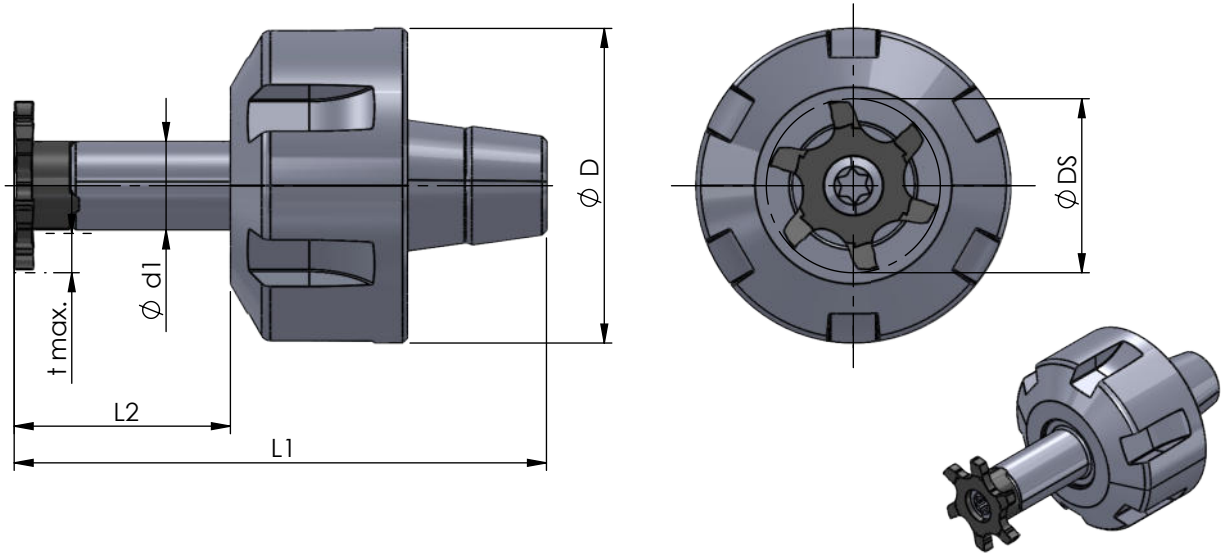

Abmessungen und Beschreibungen  
gelten für alle Varianten

dimensions and descriptions are  
valid for all versions

Abmessungen in mm

dimensions in mm



Bestellnummer part number	Ø d1	L2	Ø D	L1	Spannmutter / Gewinde clamping nut / thread	Typ: t max./ Schneidkreis-Ø DS	Spannschraube screw	Schraubenschlüssel wrench	Anzugs- drehmoment torque	für Schneideinsatz for insert
ZH18.ER11.0922.19	9	22	19	42.0	ER11.1219.SP / M14x0.75	Z18: 3.5 / 17.7 Z618: 4 / 17.7 Z620: 5 / 19.7	M4-MM	T15F	4.5 Nm	Z18... Z618... Z620...
ZH18.ER11.0922.16	9	22	16	42.0	ER11.1216.SP / M13x0.75					
ZH18.ER16.0922.32	9	22	32	52.0	ER16.1832.SP / M22x1.5					
ZH18.ER16.0922.22	9	22	22	52.0	ER16.1822.SP / M19x1.0					
ZH18.ER16.0922.25	9	22	25	52.0	ER16.1825.SP / M19x1.0					
ZH18.ER20.0922.35	9	22	35	56.5	ER20.1935.SP / M25x1.5					
ZH18.ER20.0922.28	9	22	28	56.5	ER20.1928.SP / M24x1.0					
ZH18.ER25.0922.42	9	22	42	60.0	ER25.2042.SP / M32x1.5					
ZH18.ER25.0922.35	9	22	35	60.0	ER25.2035.SP / M30x1.0					

Bestellbeispiel:  
ZH18.ER11.0922.19

order-example:  
ZH18.ER11.0922.19