

**MINIMILL**

Nut- und Formzirkularfräsen

groove milling by circular interpolation

**Typ ZH22**

Frälerschaft Stahl

D min. 22 mm

milling shank steel

D min. 22 mm

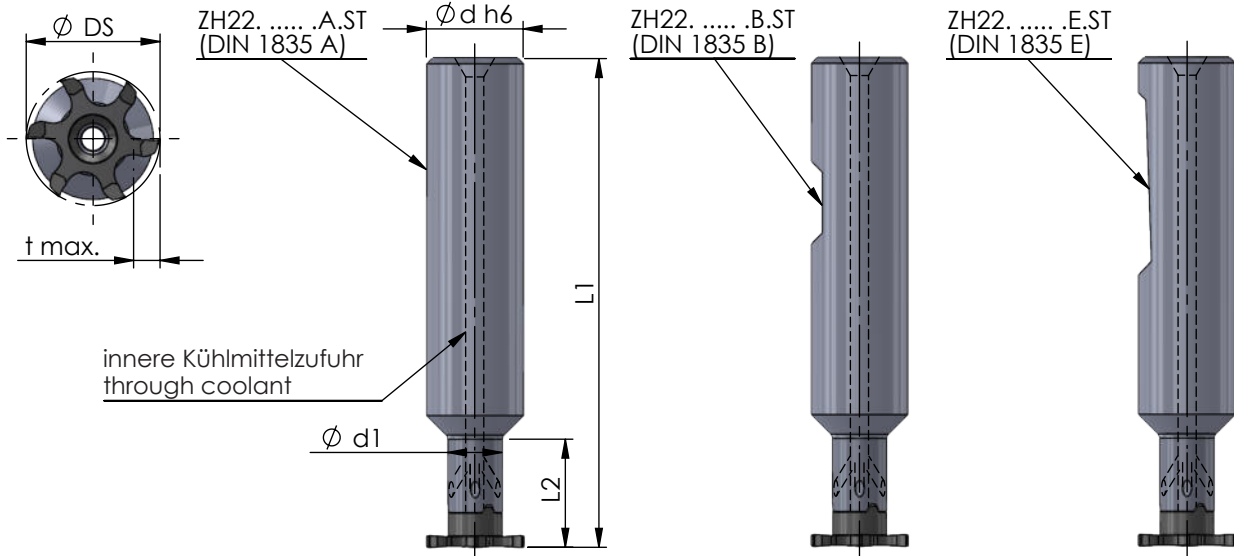

Abmessungen und Beschreibungen gelten für alle Varianten

dimensions and descriptions are valid for all versions

Abmessungen in mm

dimensions in mm

Bestellnummer part number	$\varnothing d h6$	d1	L1	L2	Typ: t max./ Schneidkreis- $\varnothing DS$	Spannschraube screw	Schraubenschlüssel wrench	Anzugs- drehmoment torque	für Schneideinsatz for insert
ZH22.1011.10.A.ST	10	11.3	60	10.7	Z22: 4.5 / 21.7 Z622: 4.5 / 21.7 Z33: 10 / 32.7 Z637: 12 / 36.7 Z640: 13.5 / 39.7	M5-MM	T20F	7.0 Nm	Z22... Z622... Z33... Z637... Z640...
ZH22.1311.25.A.ST	13	11.3	70	25.7					
ZH22.1612.24.A.ST /...B.ST /...E.ST	16	12	80	24					

Bestellbeispiel:  
ZH22.1612.24.A.ST

order-example:  
ZH22.1612.24.A.ST