

# MINIMILL

Nut- und Formzirkularfräsen

groove milling by circular interpolation

# Typ ZH22

Frälerschaft Hartmetall

D min. 22 mm

milling shank carbide

D min. 22 mm

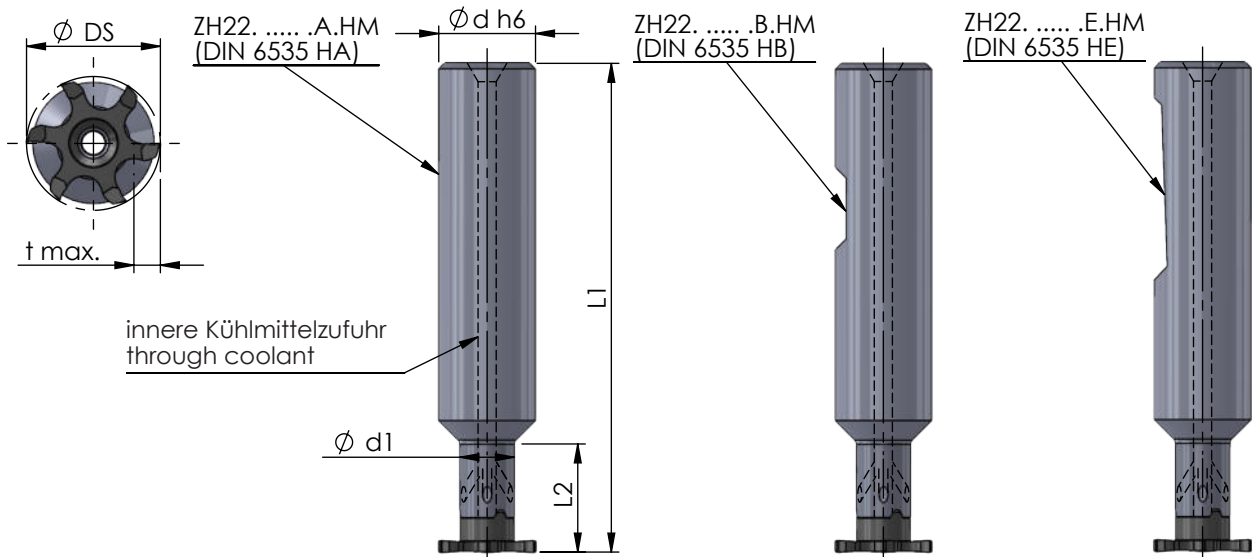

Abmessungen und Beschreibungen gelten für alle Varianten

dimensions and descriptions are valid for all versions

Abmessungen in mm

dimensions in mm

Bestellnummer part number	Ø d h6	Ø d (inch)	Ø d1	L1	L2	Typ: t max./ Schneidkreis-Ø DS	Spannschraube screw	Schraubenschlüssel wrench	Anzugs- drehmoment torque	für Schneideinsatz for insert	
ZH22.1212.42.A.HM /...B.HM /...E.HM	12	-	100	42		Z22: 4.5 / 21.7 Z622: 4.5 / 21.7 Z33: 10 / 32.7 Z637: 12 / 36.7 Z640: 13.5 / 39.7	M5-MM	T20F	7.0 Nm	Z22... Z622... Z33... Z637... Z640...	
ZH22.U1212.42.A.HM /...B.HM	12.7	1/2"	-	100	42						
ZH22.1212.60.A.HM /...B.HM /...E.HM	12	-	130	60							
ZH22.U1212.60.A.HM /...B.HM	12.7	1/2"	-	130	60						
ZH22.U1511.30.A.HM /...B.HM	15.875	5/8"	11.5	90	30						
ZH22.U1512.42.A.HM /...B.HM	15.875	5/8"	12	100	42						
ZH22.U1512.60.A.HM /...B.HM	15.875	5/8"	12	130	60						
ZH22.U1512.85.A.HM /...B.HM	15.875	5/8"	12	160	85						
ZH22.1611.30.A.HM /...B.HM /...E.HM	16	-	11.5	90	30						
ZH22.1612.42.A.HM /...B.HM /...E.HM	16	-	12	100	42						
ZH22.1612.60.A.HM /...B.HM /...E.HM	16	-	12	130	60						
ZH22.1612.85.A.HM /...B.HM /...E.HM	16	-	12	160	85						
ZH22.2016.45.A.HM /...B.HM /...E.HM	20	-	16	110	45						t max. reduziert
ZH22.2016.65.A.HM /...B.HM /...E.HM	20	-	16	130	65						t max. reduced

Hinweis:  
Hartmetall-Frälerschäfte mit beschädigter  
Schneidplattenaufnahme können durch unseren  
Reparaturservice instand gesetzt werden.

note:  
carbide-toolholder with damaged seating can be  
repaired by Dümmel.

Bestellbeispiel:  
ZH22.2016.65.A.HM

order-example:  
ZH22.2016.65.A.HM