

MINIMILL

Nut- und Formzirkularfräsen

groove milling by circular interpolation

Typ ZH28

Frälerschaft Stahl

milling shank steel

D min. 25 mm

D min. 25 mm

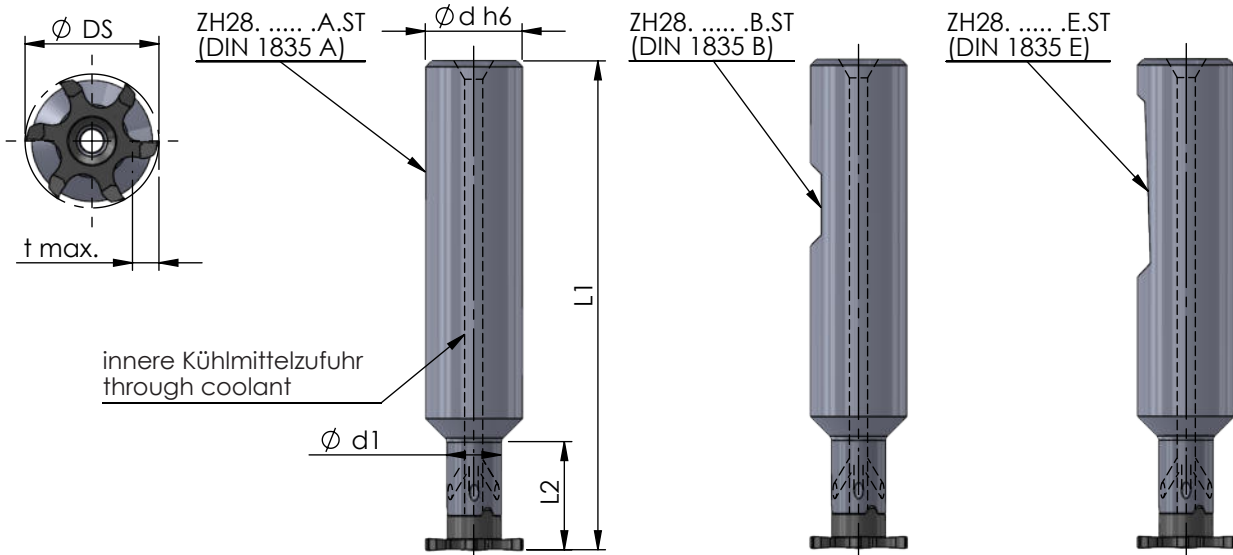

Abmessungen und Beschreibungen gelten für alle Varianten

dimensions and descriptions are valid for all versions

Abmessungen in mm

dimensions in mm



Bestellnummer part number					Typ: t max./ Schneidkreis- $\varnothing DS$	Spannschraube screw	Schraubenschlüssel wrench	Anzugs- drehmoment torque	für Schneideinsatz for insert
	$\varnothing d h6$	d1	L1	L2					
ZH28.1314.10.A.ST	13	14	70	10.7	Z25: 5 / 24,8 Z28: 6,5 / 27,7 Z628: 6,5 / 27,7 Z32: 8,5 / 31,7 Z635: 10 / 34,7	M5-MM	T20F	7.0 Nm	Z25... Z28... Z628... Z32... Z635...
ZH28.2014.35.A.ST / ...B.ST	20	14	100	35.7					

Bestellbeispiel:
ZH28.2014.35.A.ST

order-example:
ZH28.2014.35.A.ST