



MINIMILL

Nut- und Formzirkularfräsen

groove milling by circular interpolation

Typ ZH28

Fräseschaft Hartmetall

D min. 25 mm

milling shank carbide

D min. 25 mm

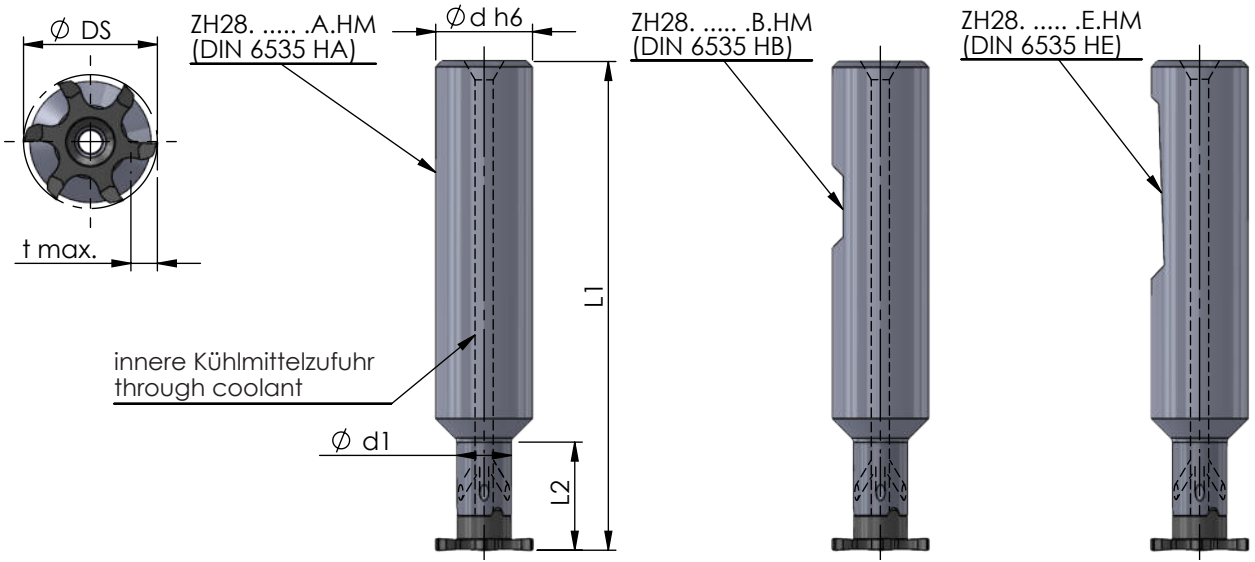

Abmessungen und Beschreibungen gelten für alle Varianten

dimensions and descriptions are valid for all versions

Abmessungen in mm

dimensions in mm

Bestellnummer part number	$\varnothing d h6$	$\varnothing d$ (inch)	$\varnothing d1$	L1	L2	Typ: t max./ Schneidkreis- $\varnothing DS$	Spannschraube screw	Schraubenschlüssel wrench	Anzugs- drehmoment torque	für Schneideinsatz for insert
ZH28.U1514.42.A.HM /...B.HM	15.875	5/8"	14.3	100	42	Z25: 5 / 24.8 Z28: 6.5 / 27.7 Z628: 6.5 / 27.7 Z32: 8.5 / 31.7 Z635: 10 / 34.7	M5-MM	T20F	7.0 Nm	Z25... Z28... Z628... Z32... Z635...
ZH28.U1514.60.A.HM /...B.HM	15.875	5/8"	14.3	130	60					
ZH28.U1514.85.A.HM /...B.HM	15.875	5/8"	14.3	160	85					
ZH28.1614.42.A.HM /...B.HM /...E.HM	16		14.3	100	42					
ZH28.1614.60.A.HM /...B.HM /...E.HM	16		14.3	130	60					
ZH28.1614.85.A.HM /...B.HM /...E.HM	16		14.3	160	85					
ZH28.2013.35.A.HM /...B.HM /...E.HM	20		13.5	104	35					
ZH28.2014.85.A.HM /...B.HM /...E.HM	20		14.3	160	85					

Hinweis:
Hartmetall-Fräseschäfte mit beschädigter
Schneidplattenaufnahme können durch unseren
Reparaturservice instand gesetzt werden.

note:
carbide-toolholder with damaged seating can be
repaired by Dümmel.

Bestellbeispiel:
ZH28.2014.85.A.HM

order-example:
ZH28.2014.85.A.HM