

MINIMILL

Nut- und Formzirkularfräsen

groove milling by circular interpolation

Typ ZH28

Fräferschaft Schwermetall

D min. 28 mm

milling shank heavy metal

D min. 28 mm

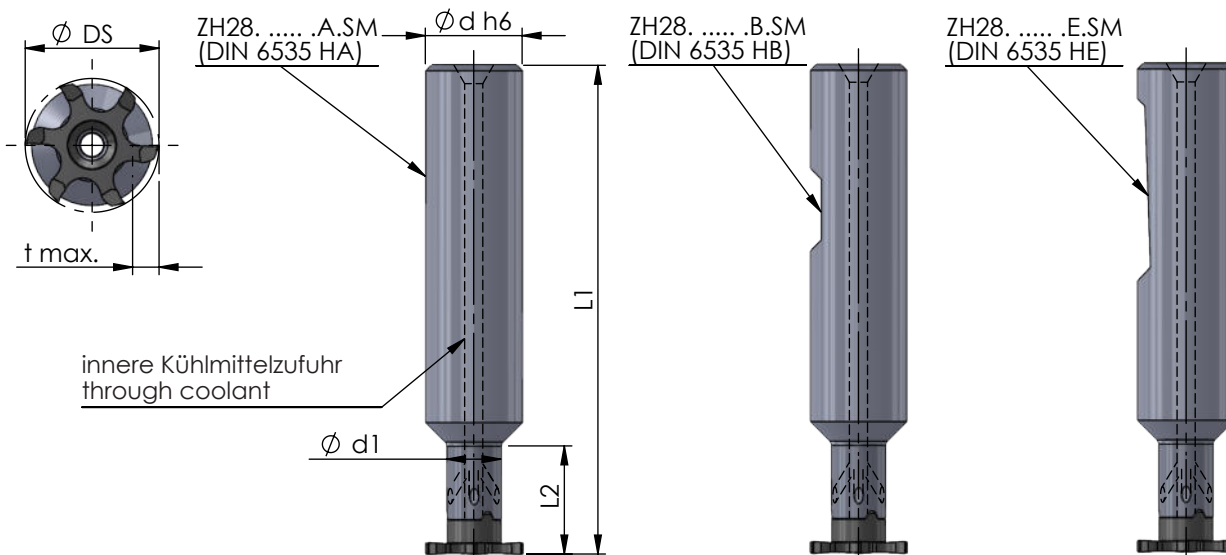

Abmessungen und Beschreibungen gelten für alle Varianten

dimensions and descriptions are valid for all versions

Abmessungen in mm

dimensions in mm



Bestellnummer part number	$\phi d h6$	d1 *	L1	L2	Typ: t max. / * Schneidkreis- ϕDS	Spannschraube screw	Schraubenschlüssel wrench	Anzugs- drehmoment torque	für Schneideinsatz for insert
ZH28.2015.20.A.SM / ...B.SM / ...E.SM	20	15	130	20	Z28: 6.5 / 27.7 Z628: 6.5 / 27.7 Z32: 8.5 / 31.7 Z635: 10 / 34.7	M5-MM	T20F	7.0 Nm	Z28... Z628... Z32... Z635...
ZH28.2020.35.A.SM / ...B.SM / ...E.SM	20	20	145	-					
ZH28.2015.30.A.SM / ...B.SM / ...E.SM	20	15	160	30					
ZH28.2020.90.A.SM / ...B.SM / ...E.SM	20	20	200	-					

* Achtung:
Durch die extrastabile Ausführung ist das t max. reduziert.

* attention:
The measure t max. is reduced by the extra-stable implementation.

Bestellbeispiel:
ZH28.2020.90.A.SM

order-example:
ZH28.2020.90.A.SM