

## MINIMILL

Nut- und Formzirkularfräsen

groove milling by circular interpolation

## Typ ZH28.ER

Fräseschaft,  
für Spannzangenfutter (DIN 6499)

D min. 25 mm

milling shank,  
for collet chucks (DIN 6499)

D min. 25 mm

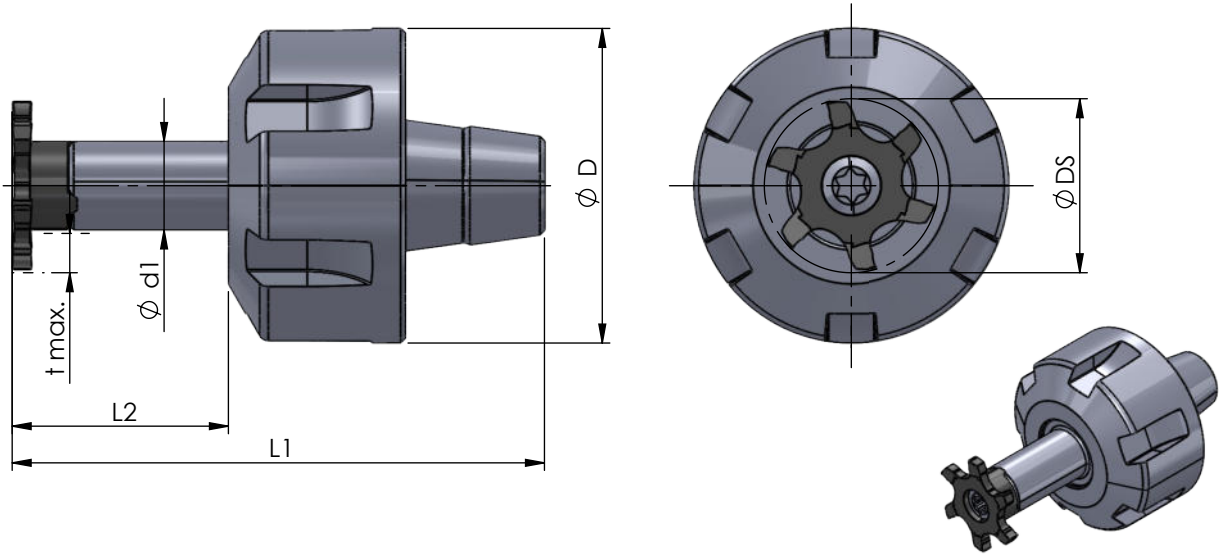

Abmessungen und Beschreibungen  
gelten für alle Varianten

dimensions and descriptions are  
valid for all versions

Abmessungen in mm

dimensions in mm

Bestellnummer part number	Ø d1	L2	Ø D	L1	Spannmutter / Gewinde clamping nut / thread	Typ: t max./ Schneidkreis-Ø DS	Spannschraube screw	Schraubenschlüssel wrench	Anzugs- drehmoment torque	für Schneideinsatz for insert
ZH28.ER20.1435.35	14	35	35	69.5	ER20.1935.SP / M25x1.5	Z25: 5 / 24.8 Z28: 6.5 / 27.7 Z628: 6.5 / 27.7 Z32: 8.5 / 31.7 Z635: 10 / 34.7	M5-MM	T20F	7.0 Nm	Z25... Z28... Z628... Z32... Z635...
ZH28.ER20.1435.28	14	35	28	69.5	ER20.1928.SP / M24x1.0					
ZH28.ER25.1419.42	14	19	42	63	ER25.2042.SP / M32x1.5					
ZH28.ER25.1419.35	14	19	35	63	ER25.2035.SP / M30x1.0					
ZH28.ER25.1435.42	14	35	42	73	ER25.2042.SP / M32x1.5					
ZH28.ER25.1435.35	14	35	35	73	ER25.2035.SP / M30x1.0					
ZH28.ER32.1419.50	14	19	50	63	ER32.2350.SP / M40x1.5					
ZH28.ER32.1435.50	14	35	50	79	ER32.2350.SP / M40x1.5					

Bestellbeispiel:  
ZH28.ER20.1435.35

order-example:  
ZH28.ER20.1435.35