

MINIMILL

Nut- und Formzirkularfräsen

groove milling by circular interpolation

Typ Z612 / Z612.X

Nutfräsen allgemein

groove milling general use

D min. 12 mm
t max. = 2

D min. 12 mm
t max. = 2

Z612 geradverzahnt / spur-toothed

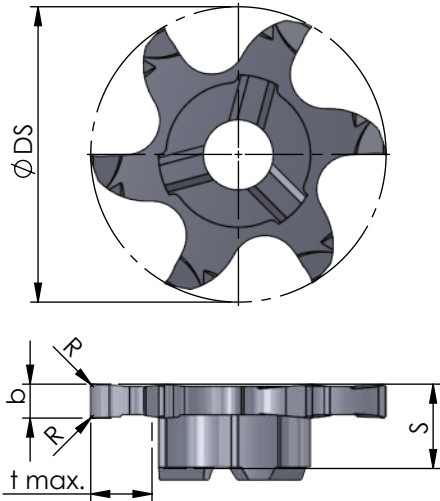

Z612.X kreuzverzahnt / staggered-toothed

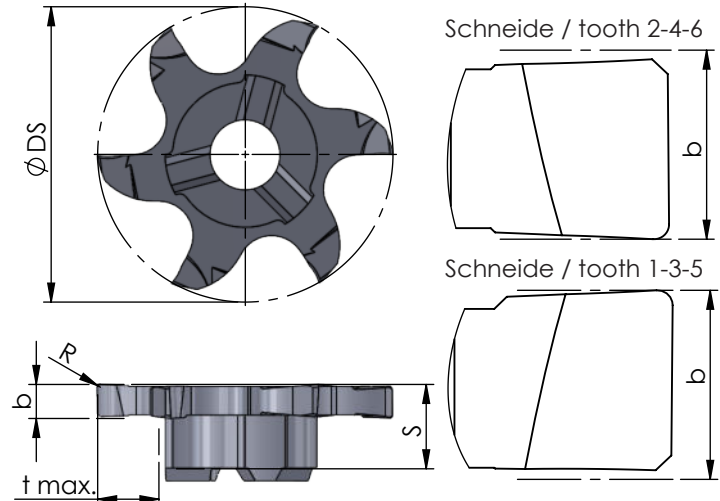

Abmessungen in mm

dimensions in mm



Bestellnummer part number	D min.	S	R	Ø DS	b +0.02	t max.	Zähnezahl number of teeth	Material			für Fräterschaft for milling shank
								K10F	AL41F	P18C	
Z612.0150.02	12	3.5	0.2	11.7	1.5	2.0	6	●			ZH10...
Z612.X150.02	12	3.5	0.2	11.7	1.5	2.0	6		●		
Z612.0200.02	12	3.5	0.2	11.7	2.0	2.0	6		●		
Z612.X200.02	12	3.5	0.2	11.7	2.0	2.0	6		●		

Weitere HM Sorten können Sie in der Sortenübersicht im Kapitel "Technische Hinweise" und der Preisliste finden.

Bestellbeispiel:
für Sorte AL41F:
Z612.0150.02/AL41F

More carbide grades you can find in the grades summary in the chapter "technical instructions" and in the price list.

order-example:
grade AL41F:
Z612.0150.02/AL41F