

MINIMILL

Nut- und Formzirkularfräsen

groove milling by circular interpolation

Typ Z14

Nutfräsen allgemein

groove milling general use

D min. 14 mm
t max. = 2.5

D min. 14 mm
t max. = 2.5

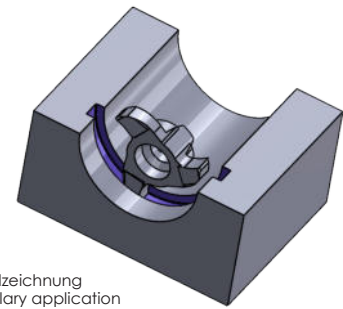
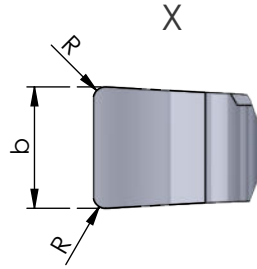
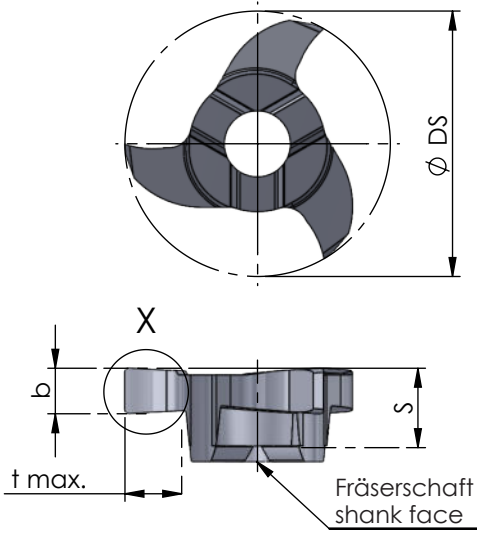

Beispielzeichnung
exemplary application

Abmessungen in mm

dimensions in mm

Bestellnummer part number	D min.	S	R	Ø DS	b +0.02	t max.	Zähnezahl number of teeth				für Fräterschaft for milling shank
								K10F	AL41F	P18C	
Z14.0100.00	14	4.5	0.1	13.7	1.0	2.5	3	●			
Z14.0150.00	14	4.5	0.2	13.7	1.5	2.5	3	●			
Z14.0200.02	14	4.5	0.2	13.7	2.0	2.5	3	●			
Z14.0250.02	14	4.5	0.2	13.7	2.5	2.5	3	●			ZH14...

Weitere HM Sorten können Sie in der Sortenübersicht im Kapitel "Technische Hinweise" und der Preisliste finden.

Bestellbeispiel:
für Sorte AL41F:
Z14.0150.00/AL41F

More carbide grades you can find in the grades summary in the chapter "technical instructions" and in the price list.

order-example:
grade AL41F:
Z14.0150.00/AL41F