

MINIMILL

Nut- und Formzirkularfräsen

groove milling by circular interpolation

Typ Z18

Sicherungsringe DIN 471 / 472
und Nutfräsen allgemein

D min. 18 mm
t max. ≤ 3.5

for circlip grooves DIN 471 / 472
and groove milling general use

D min. 18 mm
t max. ≤ 3.5

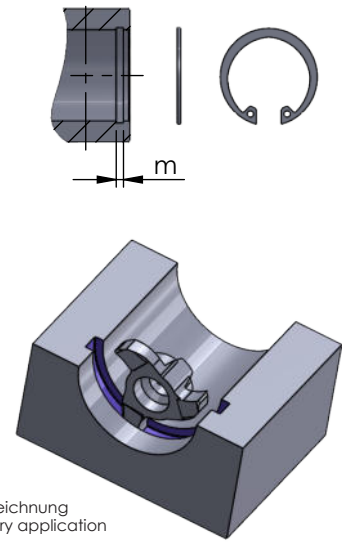
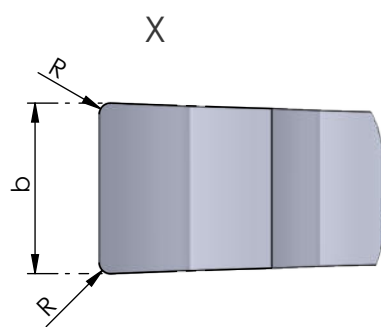
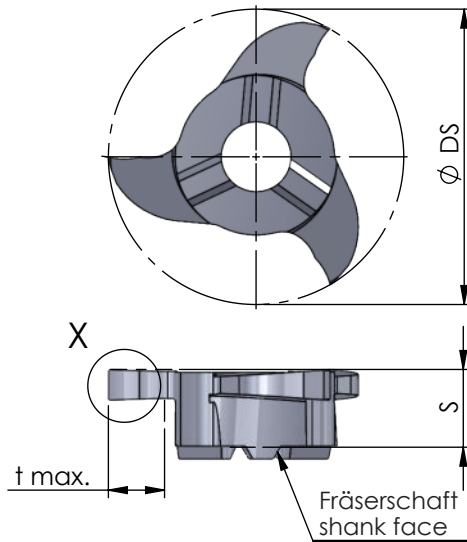

Beispielzeichnung
exemplary application

Abmessungen in mm

dimensions in mm

Bestellnummer part number	D min.	Nut-Maß m groove dim. m DIN 471 / DIN 472	S	R	Ø DS	b +0.02 (* b -0.02)	b (inch)	t max.	Zähnezahl number of teeth	Material			für Fräseschaft for milling shank
										K10F	AL41F	P18C	
Z18.0070.00	18	0.7	5.6	-	17.7	0.74*		1.5	3	●			ZH18...
Z18.0080.00	18	0.8	5.6	-	17.7	0.84*		1.7	3	●			
Z18.0090.00	18	0.9	5.6	-	17.7	0.94*		1.9	3	●			
Z18.0110.00	18	1.1	5.8	-	17.7	1.21*		3.5	3	●			
Z18.0117.00	18	-	5.8	-	17.7	1.17	0.046"	3.5	3	●			
Z18.0130.00	18	1.3	5.8	0.1	17.7	1.41*		3.5	3	●			
Z18.0142.01	18	-	5.8	0.1	17.7	1.42	0.056"	3.5	3	●			
Z18.0150.00	18	-	5.8	0.2	17.7	1.50		3.5	3	●			
Z18.0157.02	18	-	5.8	0.2	17.7	1.57	0.062"	3.5	3	●			
Z18.0160.00	18	1.6	5.8	0.1	17.7	1.71*		3.5	3	●			
↳ ...													

Weitere HM Sorten können Sie in der Sortenübersicht im Kapitel "Technische Hinweise" und der Preisliste finden.

Bestellbeispiel:
für Sorte AL41F:
Z18.0110.00/AL41F

More carbide grades you can find in the grades summary in the chapter "technical instructions" and in the price list.

order-example:
grade AL41F:
Z18.0110.00/AL41F