

MINIMILL

Nut- und Formzirkularfräsen

groove milling by circular interpolation

Typ Z22

Sicherungsringe DIN 471 / 472 und Nutfräsen allgemein

D min. 22 mm
t max. ≤ 4.5

for circlip grooves DIN 471 / 472 and groove milling general use

D min. 22 mm
t max. ≤ 4.5

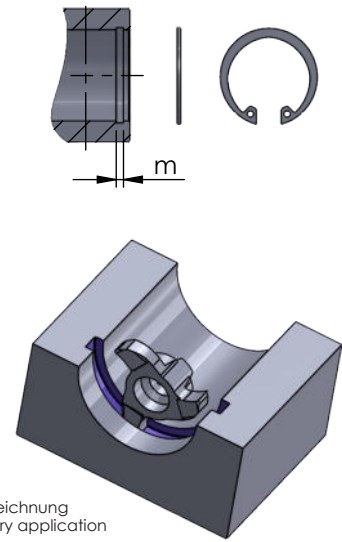
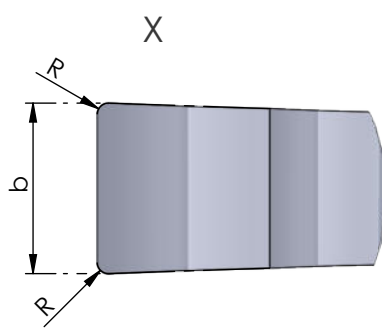
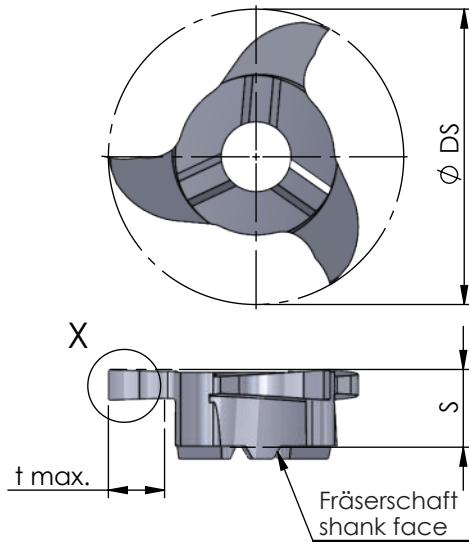

Beispielzeichnung
exemplary application

Abmessungen in mm

dimensions in mm

Bestellnummer part number	D min.	Nut-Maß m groove dim. m DIN 471 / DIN 472	S	R	Ø DS	b +0.02 (* b -0.02)	b (inch)	t max.	Zähnezahl number of teeth	K10F AL41F P18C	für Fräuserschaft for milling shank
Z22.0070.00	22	0.7	5.6	-	21.7	0.74*		1.5	3	●	ZH22...
Z22.0079.00	22	-	5.6	-	21.7	0.79	0.031"	1.5	3	●	
Z22.0080.00	22	0.8	5.6	-	21.7	0.84*		1.7	3	●	
Z22.0090.00	22	0.9	5.6	-	21.7	0.94*		1.9	3	●	
Z22.0099.00	22	-	5.6	-	21.7	0.99	0.039"	2.0	3	●	
Z22.0100.00	22	1.0	5.6	-	21.7	1.04*		2.1	3	●	
Z22.0100.01	22	-	5.6	0.10	21.7	1.00		4.5	3	●	
Z22.0110.00	22	1.1	5.7	-	21.7	1.21*		2.5	3	●	
Z22.0117.00	22	-	5.7	-	21.7	1.17	0.046"	2.5	3	●	
Z22.0130.00	22	1.3	5.7	0.10	21.7	1.41*		4.5	3	●	
Z22.0142.01	22	-	5.7	0.10	21.7	1.42	0.056"	4.5	3	●	
Z22.0150.02	22	-	5.7	0.20	21.7	1.50		4.5	3	●	
Z22.0160.00	22	1.6	5.7	0.10	21.7	1.71*		4.5	3	●	
Z22.0185.02	22	1.85	5.7	0.20	21.7	1.96*		4.5	3	●	

↳ ...

Weitere HM Sorten können Sie in der Sortenübersicht im Kapitel "Technische Hinweise" und der Preisliste finden.

Bestellbeispiel:
für Sorte AL41F:
Z22.0110.00/AL41F

More carbide grades you can find in the grades summary in the chapter "technical instructions" and in the price list.

order-example:
grade AL41F:
Z22.0110.00/AL41F