

MINIMILL

Nut- und Formzirkularfräsen

groove milling by circular interpolation

Typ Z25

Nutfräsen allgemein

groove milling general use

D min. 25 mm
t max. = 5.0

D min. 25 mm
t max. = 5.0

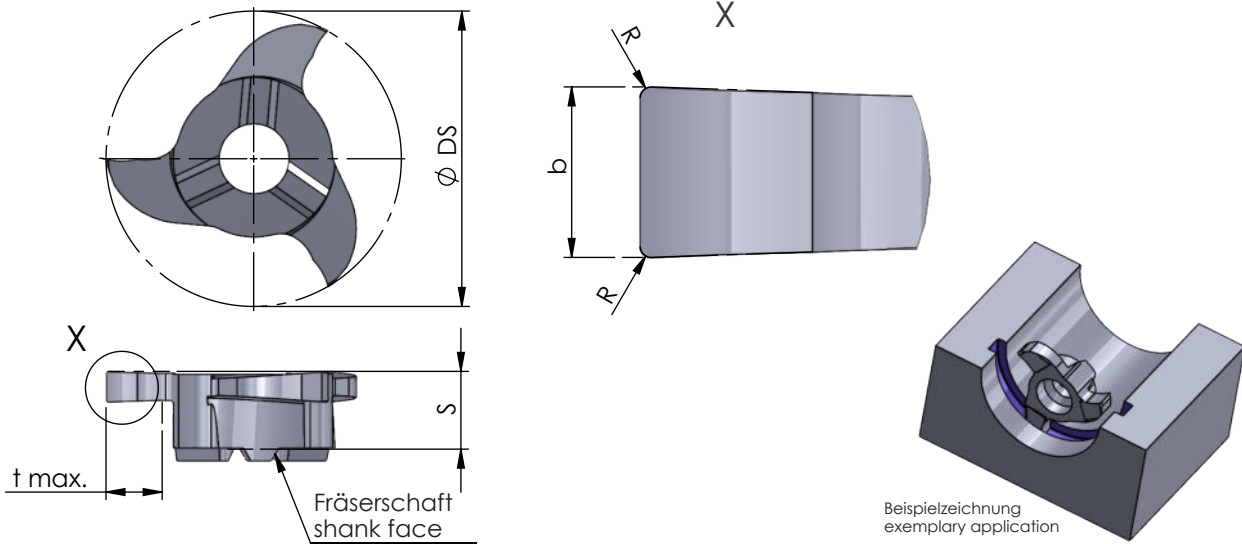

Abmessungen in mm

dimensions in mm

Bestellnummer part number	Abmessungen in mm / dimensions in mm							Zähnezahl number of teeth	Material			für Fräterschaft for milling shank
	D min.	S	R	$\varnothing DS$	b +0.02	b (inch)	t max.		K10F	AL41F	P18C	
Z25.0200.02	25	6.6	0.2	24.8	2.0		5.0	3	●			ZH28...
Z25.0250.02	25	6.6	0.2	24.8	2.5		5.0	3	●			
Z25.0300.02	25	6.6	0.2	24.8	3.0		5.0	3	●			
Z25.0318.02	25	6.6	0.2	24.8	3.18	0.125"	5.0	3	●			
Z25.0350.02	25	6.6	0.2	24.8	3.5		5.0	3	●			
Z25.0400.02	25	6.6	0.2	24.8	4.0		5.0	3	●			

Weitere HM Sorten können Sie in der Sortenübersicht im Kapitel "Technische Hinweise" und der Preisliste finden.

Bestellbeispiel:
für Sorte AL41F:
Z25.0350.02/AL41F

More carbide grades you can find in the grades summary in the chapter "technical instructions" and in the price list.

order-example:
grade AL41F:
Z25.0350.02/AL41F