

MINIMILL

Nut- und Formzirkularfräsen

groove milling by circular interpolation

Typ Z625.X

Nutfräsen allgemein

groove milling general use

D min. 25 mm
t max. = 5

D min. 25 mm
t max. = 5

Z625.X kreuzverzahnt / staggered-toothed

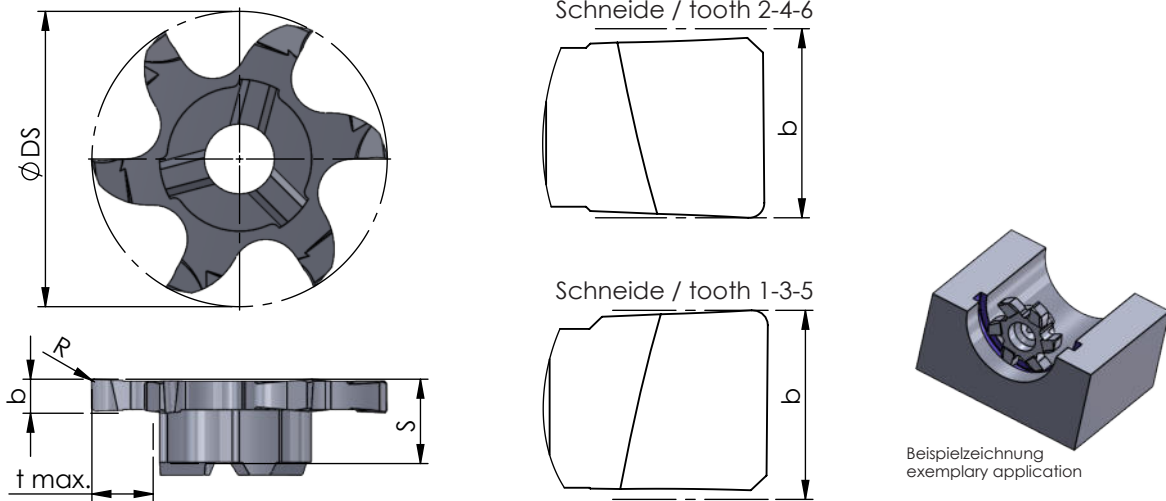

Abmessungen in mm

dimensions in mm

Bestellnummer part number	D min.	S	R	Ø DS	b +0.02	t max.	Zähnezahl number of teeth				für Fräterschaft for milling shank
								K10F	AL41F	P18C	
Z625.X250.02	25	6.4	0.2	24.8	2.5	5.0	6	●			ZH28...
Z625.X300.02	25	6.4	0.2	24.8	3.0	5.0	6		●		
Z625.X400.02	25	6.4	0.2	24.8	4.0	5.0	6			●	
Z625.X500.02	25	6.4	0.2	24.8	5.0	5.0	6			●	
Z625.X600.02	25	6.4	0.2	24.8	6.0	5.0	6			●	

Weitere HM Sorten können Sie in der Sortenübersicht im Kapitel "Technische Hinweise" und der Preisliste finden.

Bestellbeispiel:
für Sorte AL41F:
Z625.X250.02/AL41F

More carbide grades you can find in the grades summary in the chapter "technical instructions" and in the price list.

order-example:
grade AL41F:
Z625.X250.02/AL41F