

MINIMILL

Nut- und Formzirkularfräsen

groove milling by circular interpolation

Typ Z28

Nutfräsen allgemein

groove milling general use

D min. 28.3 mm
t max. = 9.3

D min. 28.3 mm
t max. = 9.3

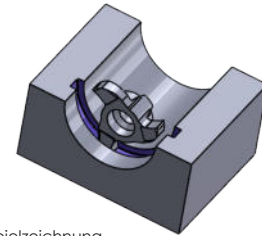
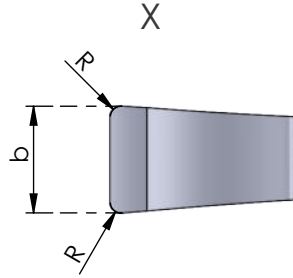
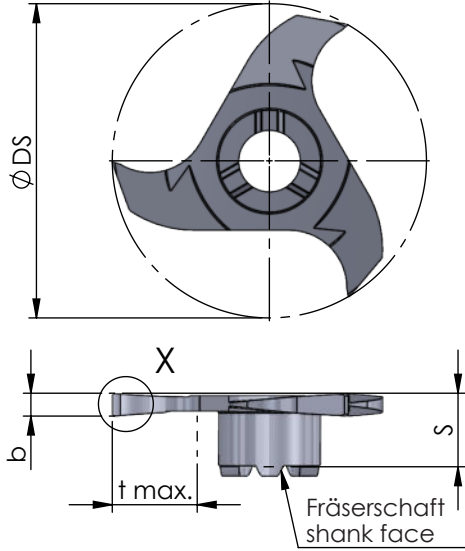

Beispielzeichnung
exemplary application

Abmessungen in mm

dimensions in mm

Bestellnummer part number	D min.	S	R	Ø DS	b -0.02	t max.	Zähnezahl number of teeth				für Frälerschaft for milling shank
								K10F	AL41F	P18C	
Z28.0150.02.9	28.3	6.5	0.2	28	1.5	9.3	3	●			
Z28.0200.02.9	28.3	6.5	0.2	28	2.0	9.3	3		●		ZH33...
Z28.0250.02.9	28.3	6.5	0.2	28	2.5	9.3	3		●		

Weitere HM Sorten können Sie in der Sortenübersicht im Kapitel "Technische Hinweise" und der Preisliste finden.

Bestellbeispiel:
für Sorte AL41F:
Z28.0150.02.9/AL41F

More carbide grades you can find in the grades summary in the chapter "technical instructions" and in the price list.

order-example:
grade AL41F:
Z28.0150.02.9/AL41F