

MINIMILL

Nut- und Formzirkularfräsen

groove milling by circular interpolation

Typ Z628 / Z628.X

Sicherungsringe DIN 471 / 472 und Nutfräsen allgemein

D min. 28 mm
t max. = 6.5

for circlip grooves DIN 471 / 472 and groove milling general use

D min. 28 mm
t max. = 6.5



Z628 geradverzahnt / spur-toothed

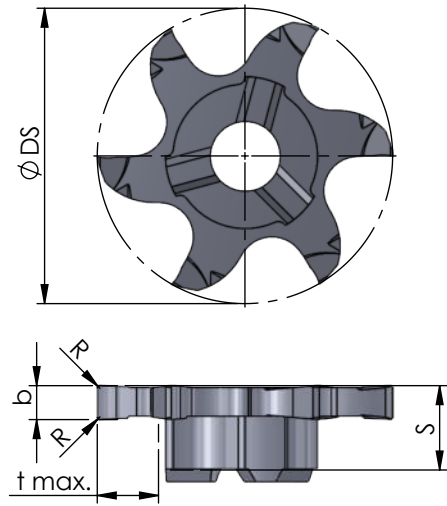

Z628.X kreuzverzahnt / staggered-toothed

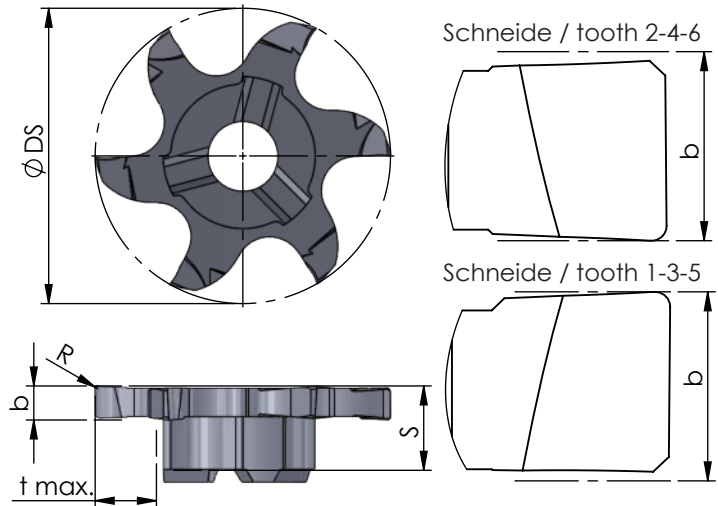

Abmessungen in mm

dimensions in mm



Bestellnummer part number	D min.	Nut-Maß m groove dim. m DIN 471 / DIN 472	S	R	Ø DS	b +0.02 (* b -0.02)	t max.	Zähnezahl number of teeth	K10F AL41F P18C	für Fräterschaft for milling shank
Z628.0100.01	28	-	6.0	0.1	27.7	1.0	6.5	6	●	ZH28...
Z628.0150.01	28	-	6.4	0.1	27.7	1.5	6.5	6	●	
Z628.0185.02	28	1.85	6.4	0.2	27.7	1.96 *	6.5	6	●	
Z628.0200.02	28	-	6.4	0.2	27.7	2.0	6.5	6	●	
Z628.0215.02	28	2.15	6.2	0.2	27.7	2.26 *	6.5	6	●	
Z628.0250.02	28	-	6.4	0.2	27.7	2.5	6.5	6	●	
Z628.X250.02	28	-	6.2	0.2	27.7	2.5	6.5	6	●	
Z628.0300.02	28	-	6.4	0.2	27.7	3.0	6.5	6	●	
Z628.X300.02	28	-	6.2	0.2	27.7	3.0	6.5	6	●	
Z628.0400.02	28	-	6.4	0.2	27.7	4.0	6.5	6	●	
Z628.X400.02	28	-	6.2	0.2	27.7	4.0	6.5	6	●	
Z628.0500.02	28	-	6.4	0.2	27.7	5.0	6.5	6	●	
Z628.X500.02	28	-	6.2	0.2	27.7	5.0	6.5	6	●	
Z628.0600.02	28	-	6.4	0.2	27.7	6.0	6.5	6	●	
Z628.X600.02	28	-	6.2	0.2	27.7	6.0	6.5	6	●	

Weitere HM Sorten können Sie in der Sortenübersicht im Kapitel "Technische Hinweise" und der Preisliste finden.

Bestellbeispiel:
für Sorte AL41F: Z628.0150.01/AL41F

More carbide grades you can find in the grades summary in the chapter "technical instructions" and in the price list.

order-example:
grade AL41F: Z628.0150.01/AL41F