

**MINIMILL**

Nut- und Formzirkularfräsen

groove milling by circular interpolation

**Typ Z628**

Nutfräsen allgemein

groove milling general use

D min. 28.3 mm  
t max. = 9.3

D min. 28.3 mm  
t max. = 9.3

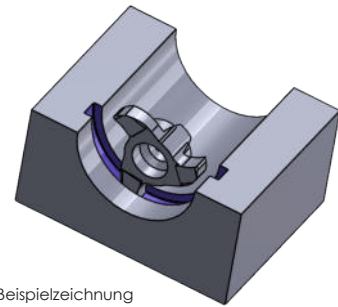
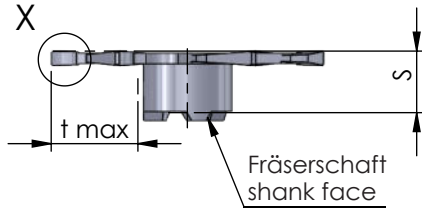
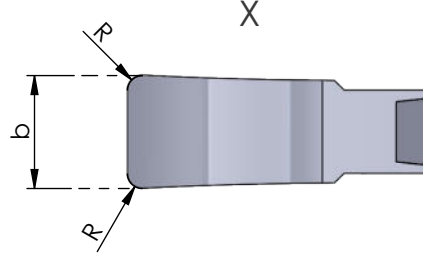
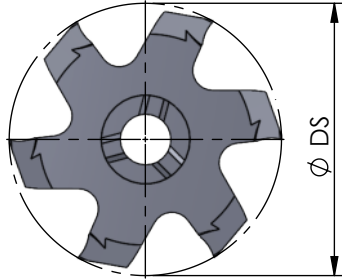

Beispielzeichnung  
exemplary application

Abmessungen in mm

dimensions in mm

Bestellnummer part number	D min.	S	R	Ø DS	b +0.02	t max.	Zähnezahl number of teeth	Material			für Frälerschaft for milling shank
								K10F	AL41F	P18C	
Z628.150.02.9	28.3	6.2	0.2	28	1.5	9.3	6	●			
Z628.200.02.9	28.3	6.2	0.2	28	2.0	9.3	6	●			ZH33...

neu

Weitere HM Sorten können Sie in der Sortenübersicht im Kapitel "Technische Hinweise" und der Preisliste finden.

Bestellbeispiel:  
für Sorte AL41F:  
Z628.150.02.9/AL41F

More carbide grades you can find in the grades summary in the chapter "technical instructions" and in the price list.

order-example:  
grade AL41F:  
Z628.150.02.9/AL41F