

MINIMILL

Nut- und Formzirkularfräsen

groove milling by circular interpolation

Typ Z33

Nutfräsen allgemein

groove milling general use

D min. 33 / 33.9 mm
t max. = 10 / 12

D min. 33 / 33.9 mm
t max. = 10 / 12

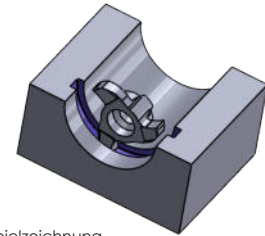
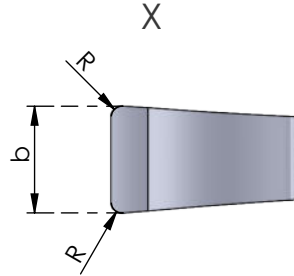
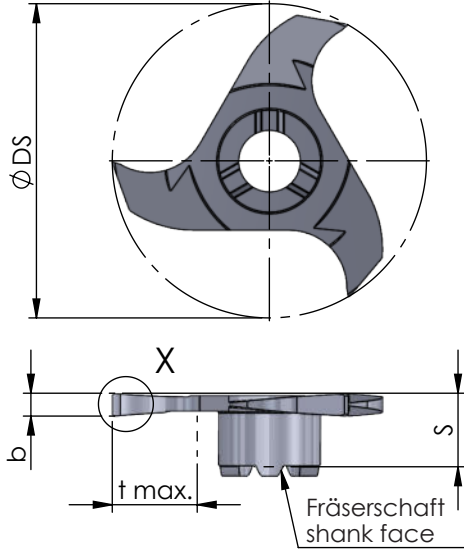

Beispielzeichnung
exemplary application

Abmessungen in mm

dimensions in mm

Bestellnummer part number	D min.	S	R	Ø DS	b -0.02	t max.	Zähnezahl number of teeth	Material			für Fräseschaft for milling shank
								K10F	AL41F	P18C	
Z33.110.42.10	33	6.5	0.2	32.7	1.10	10	3	●			ZH22...
Z33.120.42.10	33	6.5	0.2	32.7	1.20	10	3	●			
Z33.132.42.10	33	6.5	0.2	32.7	1.32	10	3	●			
Z33.150.42.10	33	6.5	0.2	32.7	1.50	10	3	●			
Z33.160.42.10	33	6.5	0.2	32.7	1.60	10	3	●			
Z33.170.42.10	33	6.5	0.2	32.7	1.70	10	3	●			
Z33.200.42.10	33	6.5	0.2	32.7	2.00	10	3	●			
Z33.250.42.10	33	6.5	0.2	32.7	2.50	10	3	●			
Z33.170.42.12	33.9	6.5	0.2	33.6	1.70	12	3	●			ZH33...

Weitere HM Sorten können Sie in der Sortenübersicht im Kapitel "Technische Hinweise" und der Preisliste finden.

Bestellbeispiel:
für Sorte AL41F:
Z33.200.42.10/AL41F

More carbide grades you can find in the grades summary in the chapter "technical instructions" and in the price list.

order-example:
grade AL41F:
Z33.200.42.10/AL41F