

# MINIMILL

Nut- und Formzirkularfräsen

groove milling by circular interpolation

# Typ Z635 / Z635.X

Nutfräsen allgemein

groove milling general use

D min. 35 mm  
t max. = 10

D min. 35 mm  
t max. = 10

## Z635 geradverzahnt / spur-toothed

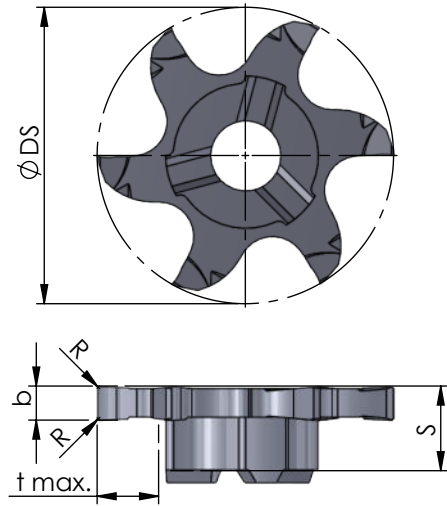

## Z635.X kreuzverzahnt / staggered-toothed

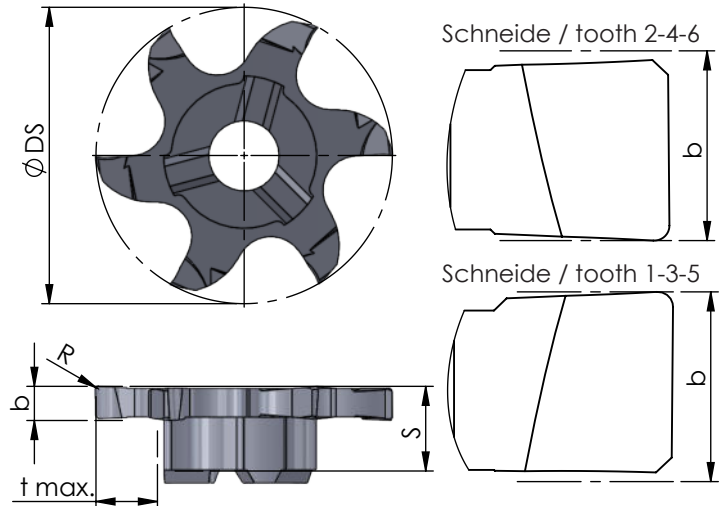

Abmessungen in mm

dimensions in mm



Bestellnummer part number	D min.	S	R	Ø DS	b +0.02	t max.	Zähnezahl number of teeth	K10F AL41F P18C	für Fräseschaft for milling shank
Z635.0150.01	35	6.25	0.1	34.7	1.5	10.0	6	●	ZH28...
Z635.0200.02	35	6.25	0.2	34.7	2.0	10.0	6	●	
Z635.X200.02	35	6.25	0.2	34.7	2.0	10.0	6	●	
Z635.0250.02	35	6.25	0.2	34.7	2.5	10.0	6	●	
Z635.X250.02	35	6.25	0.2	34.7	2.5	10.0	6	●	
Z635.0300.02	35	6.25	0.2	34.7	3.0	10.0	6	●	
Z635.X300.02	35	6.25	0.2	34.7	3.0	10.0	6	●	

Weitere HM Sorten können Sie in der Sortenübersicht im Kapitel "Technische Hinweise" und der Preisliste finden.

Bestellbeispiel:  
für Sorte AL41F:  
Z635.0150.01/AL41F

More carbide grades you can find in the grades summary in the chapter "technical instructions" and in the price list.

order-example:  
grade AL41F:  
Z635.0150.01/AL41F