

MINIMILL

Nut- und Formzirkularfräsen

groove milling by circular interpolation

Typ Z637 / Z640

Nutfräsen, Trennfräsen und Schlitzfräsen

groove and keyway milling

D min. 37 / 40 mm
t max. = 12 / 13.5
b = 0.4 - 0.8 mm

D min. 37 / 40 mm
t max. = 12 / 13.5
b = 0.4 - 0.8 mm

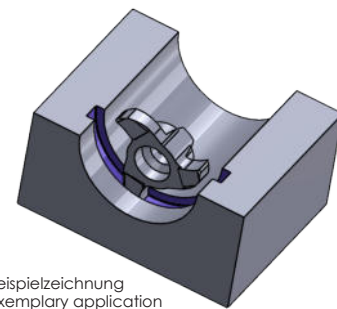
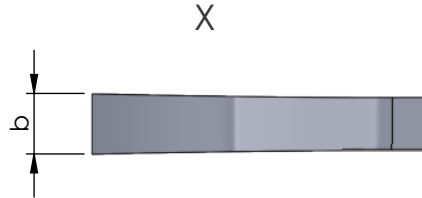
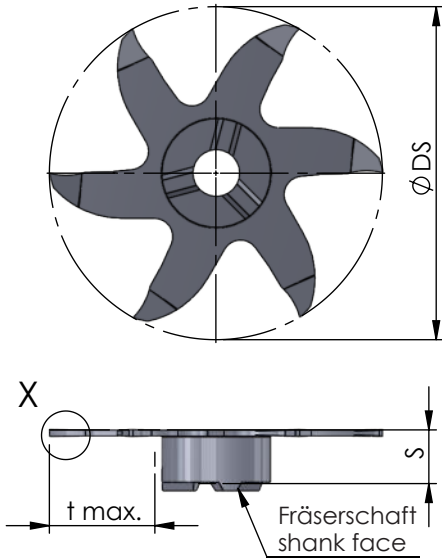

Beispielzeichnung
exemplary application

Abmessungen in mm

dimensions in mm

Bestellnummer part number	D min.	S	Ø DS	b +0.05	t max.	Zähnezahl number of teeth				für Fräaserschaft for milling shank
							K10F	AL41F	P18C	
Z640.0040.00	40	6.0	39.7	0.4	13.5	6		●		ZH22...
Z637.0050.00	37	6.0	36.7	0.5	12.0	6		●		
Z640.0050.00	40	6.0	39.7	0.5	13.5	6		●		
Z637.0060.00	37	5.7	36.7	0.6	12.0	6		●		
Z640.0060.00	40	5.7	39.7	0.6	13.5	6		●		
Z637.0080.00	37	6.0	36.7	0.8	12.0	6		●		
Z640.0080.00	40	6.0	39.7	0.8	13.5	6		●		

Weitere HM Sorten können Sie in der Sortenübersicht im Kapitel "Technische Hinweise" und der Preisliste finden.

Bestellbeispiel:
für Sorte AL41F:
Z640.0040.00/AL41F

More carbide grades you can find in the grades summary in the chapter "technical instructions" and in the price list.

order-example:
grade AL41F:
Z640.0040.00/AL41F