

MINIMILL

Nut- und Formzirkularfräsen

groove milling by circular interpolation

Typ Z635 / Z637 / Z640

Trennfräsen

slot milling

Schneidkreis-Ø Ds ab 34.7 mm
t max. = 10 / 12 / 13.5
b = 1.0 / 1.5 mm

cutting edge-Ø Ds starting at 34.7 mm
t max. = 10 / 12 / 13.5
b = 1.0 / 1.5 mm

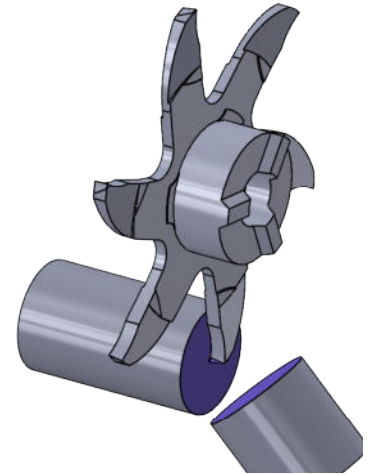
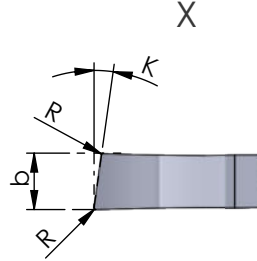
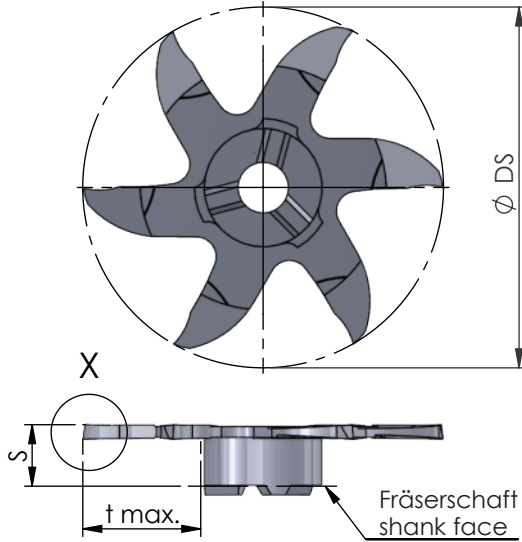

Abmessungen in mm

dimensions in mm

Bestellnummer part number	Ø DS	S	K	b+0.02	R	t max.	Zähnezahl number of teeth	K10F AL41F P18C	für Frälerschaft for milling shank
Z635.L810.005	34.7	6.25	8°	1.0	0.05	10	6	●	ZH28...
Z635.L815.005	34.7	6.25	8°	1.5	0.05	10	6	●	
Z637.L810.005	36.7	6.25	8°	1.0	0.05	12	6	●	ZH22...
Z637.L815.005	36.7	6.25	8°	1.5	0.05	12	6	●	
Z640.L810.005	39.7	6.25	8°	1.0	0.05	13.5	6	●	
Z640.L815.005	39.7	6.25	8°	1.5	0.05	13.5	6	●	

Weitere HM Sorten können Sie in der Sortenübersicht im Kapitel "Technische Hinweise" und der Preisliste finden.

Bestellbeispiel:
für Sorte AL41F:
Z635.L810.005/AL41F

More carbide grades you can find in the grades summary in the chapter "technical instructions" and in the price list.

order-example:
grade AL41F:
Z635.L810.005/AL41F