

MINIMILL

Nut- und Formzirkularfräsen

groove milling by circular interpolation

Typ Z16

Vollradius

full radius

D min. 16 mm
t max. = 3.5

D min. 16 mm
t max. = 3.5

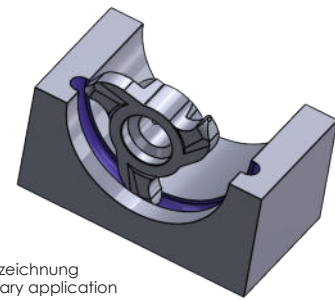
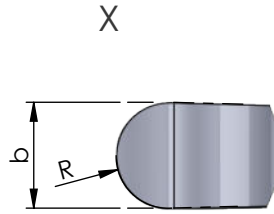
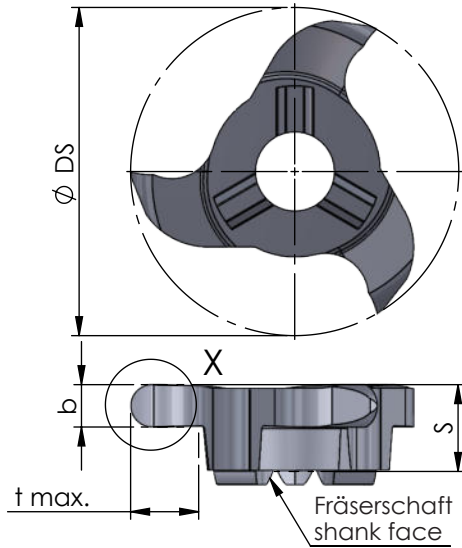

Beispielzeichnung
exemplary application

Abmessungen in mm

dimensions in mm

Bestellnummer part number	D min.	S	R	Ø DS	b +0.03	t max.	Zähnezahl number of teeth	Material			für Fräterschaft for milling shank
								K10F	AL41F	P18C	
Z16.0011.22	16	4.5	1.1	15.7	2.2	3.5	3	●			ZH14...

Weitere HM Sorten können Sie in der Sortenübersicht im Kapitel "Technische Hinweise" und der Preisliste finden.

Bestellbeispiel:
für Sorte AL41F:
Z16.0011.22/AL41F

More carbide grades you can find in the grades summary in the chapter "technical instructions" and in the price list.

order-example:
grade AL41F:
Z16.0011.22/AL41F