

MINIMILL

Nut- und Formzirkularfräsen

groove milling by circular interpolation

Typ Z610

metrisches ISO-Gewinde, Teilprofil, innen

metric ISO-thread, partial profile, internal

ab Gewindegröße M12 x 1.0

starting at thread size M12 x 1.0

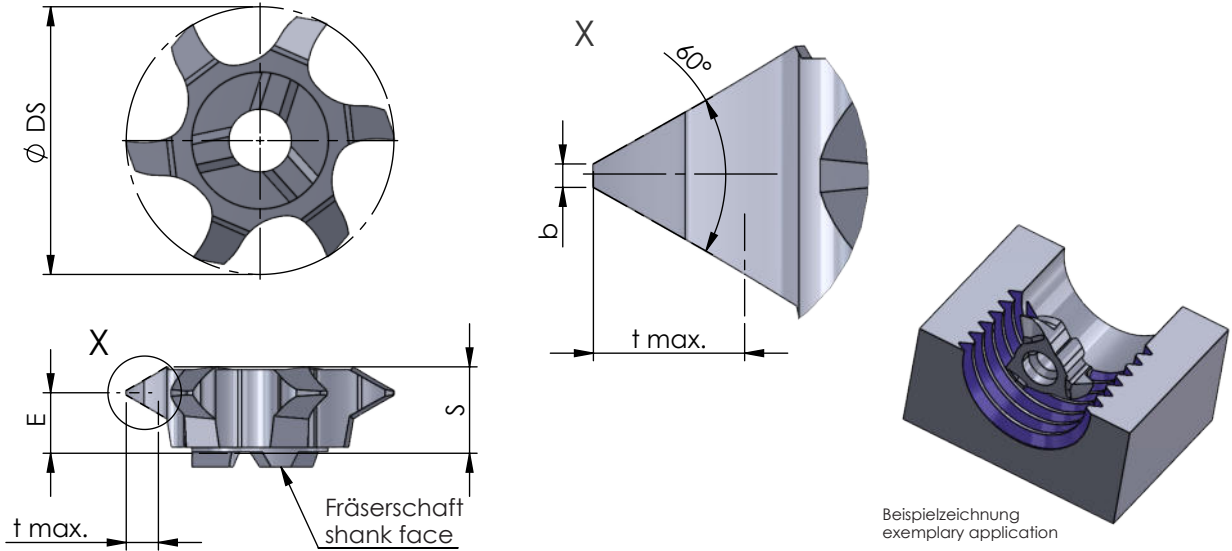

Abmessungen in mm

dimensions in mm

Bestellnummer part number	min. Gewindegröße min. thread size	Steigung P pitch P	S	E	$\varnothing DS$	b	t max.	Zähnezahl number of teeth	K10F AL41F P18C	für Fräseschaft for milling shank
Z610.0510.01	M12	1.0-1.75	3.2	2.4	9.8	0.13	1.08	6	●	ZH10...
Z610.0720.01	M14	1.0-2.0	3.2	2.2	10.1	0.13	1.25	6	●	
Z610.0815.01	M16	1.5-2.75	3.2	2.0	11.0	0.19	1.67	6	●	
Z610.2530.01	M16	2.0-3.0	3.2	1.9	11.1	0.25	1.78	6	●	

Weitere HM Sorten können Sie in der Sortenübersicht im Kapitel "Technische Hinweise" und der Preisliste finden.

Bestellbeispiel:
für Sorte AL41F:
Z610.0510.01/AL41F

More carbide grades you can find in the grades summary in the chapter "technical instructions" and in the price list.

order-example:
grade AL41F:
Z610.0510.01/AL41F