

MINIMILL

Nut- und Formzirkularfräsen

groove milling by circular interpolation

Typ Z10

metrisches ISO-Gewinde, Vollprofil, innen

metric ISO-thread, full profile, internal

ab Gewindegröße M12 x 0.75

starting at thread size M12 x 0.75

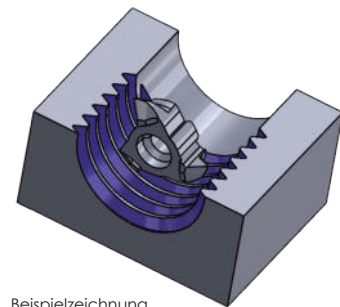
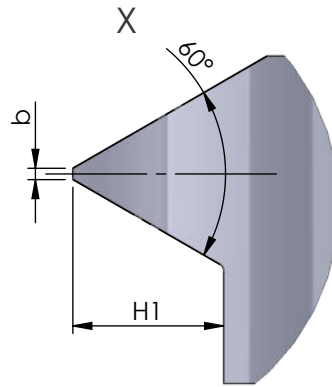
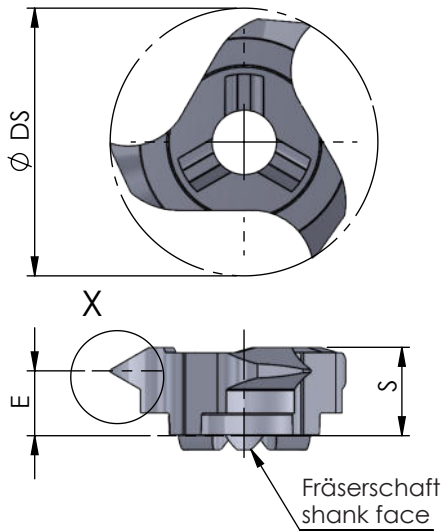

Beispielzeichnung
exemplary application

Abmessungen in mm

dimensions in mm

Bestellnummer part number	min. Gewindegröße min. thread size	Steigung P pitch P	S	E	Ø DS	b	H1	Zähnezahl number of teeth	K10F AL41F P18C	für Frälerschaft for milling shank
Z10.0407.02	M12	0.75	3.6	3.1	9.7	0.09	0.41	3	●	ZH10...
Z10.0510.02	M12	1.00	3.6	3.0	9.7	0.13	0.54	3	●	
Z10.0815.02	M14	1.50	3.6	2.8	9.7	0.19	0.81	3	●	
Z10.0917.02	M14	1.75	3.6	2.7	9.7	0.20	0.95	3	●	
Z10.1020.02	M14	2.00	3.6	2.6	9.7	0.25	1.08	3	●	
Z10.1325.02	M16	2.50	3.6	2.4	9.7	0.31	1.35	3	●	

Weitere HM Sorten können Sie in der Sortenübersicht im Kapitel "Technische Hinweise" und der Preisliste finden.

Bestellbeispiel:
für Sorte AL41F:
Z10.0407.02/AL41F

More carbide grades you can find in the grades summary in the chapter "technical instructions" and in the price list.

order-example:
grade AL41F:
Z10.0407.02/AL41F