

MINIMILL

Nut- und Formzirkularfräsen

groove milling by circular interpolation

Typ Z618

metrisches ISO-Gewinde, Vollprofil, innen

metric ISO-thread, full profile, internal

ab Gewindegröße M22 x 1,5

starting at thread size M22 x 1,5

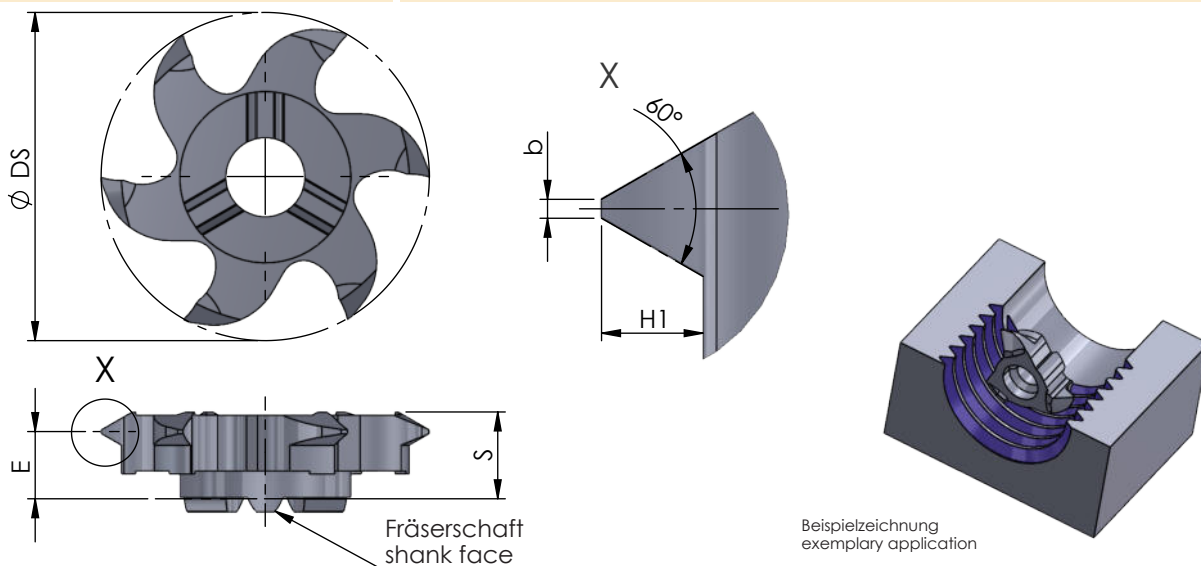

Abmessungen in mm

dimensions in mm



Bestellnummer part number	min. Gewindegröße min. thread size	Steigung P pitch P	S	E	$\varnothing DS$	b	H1	Zähnezahl number of teeth	K10F AL41F P18C	für Fräterschaft for milling shank
Z618.0815.02	M22	1.50	5.85	5.0	17.7	0.19	0.81	6	●	ZH18...
Z618.1020.02	M22	2.00	5.85	4.8	17.7	0.25	1.083	6	●	
Z618.1630.02	M27	3.00	5.85	4.6	17.7	0.38	1.62	6	●	
Z618.1835.02	M27	3.50	5.85	4.0	17.7	0.44	1.89	6	●	

Weitere HM Sorten können Sie in der Sortenübersicht im Kapitel "Technische Hinweise" und der Preisliste finden.

Bestellbeispiel:
für Sorte AL41F:
Z618.0815.02/AL41F

More carbide grades you can find in the grades summary in the chapter "technical instructions" and in the price list.

order-example:
grade AL41F:
Z618.0815.02/AL41F